

# Operation and Installation

## Automatic Transfer Switch

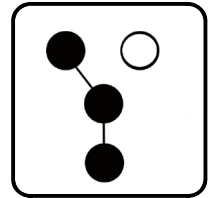

Model:

# RXT

100-400 Amp Automatic Transfer Switches

For use with Kohler® Model RESA, RESAL, or RCL generator sets  
equipped with RDC2 or DC2 generator/transfer switch controllers

**KOHLER**<sup>®</sup>  
POWER SYSTEMS

**ISO 9001**  
**KOHLER**  
POWER SYSTEMS  
NATIONALLY REGISTERED

TP-6807 12/11

# Product Identification Information

---

Product identification numbers determine service parts. Record the product identification numbers in the spaces below immediately after unpacking the products so that the numbers are readily available for future reference. Record field-installed kit numbers after installing the kits.

## Transfer Switch Identification Numbers

Record the product identification numbers from the transfer switch nameplate.

Model Designation \_\_\_\_\_

Serial Number \_\_\_\_\_

# Table of Contents

<b>Product Identification Information</b> .....	<b>2</b>
<b>Safety Precautions and Instructions</b> .....	<b>5</b>
<b>Introduction</b> .....	<b>7</b>
Nameplate .....	8
Model Designation .....	8
<b>Service Assistance</b> .....	<b>9</b>
<b>Section 1 Description</b> .....	<b>11</b>
1.1 Transfer Switch Description .....	11
1.2 Service Entrance Models .....	11
1.3 Load Centers .....	11
1.4 Controller Interface Board .....	12
1.5 Optional LED Indicator Panel .....	12
<b>Section 2 Installation</b> .....	<b>13</b>
2.1 Introduction .....	13
2.2 Receipt of Unit .....	13
2.2.1 Inspection .....	13
2.2.2 Storage .....	13
2.2.3 Unpacking .....	13
2.2.4 Lifting .....	13
2.3 Installation .....	14
2.4 Manual Operation Check .....	15
2.4.1 Manual Operation Procedure 1 .....	15
2.4.2 Manual Operation Procedure 2 .....	15
2.5 Electrical Wiring .....	16
2.5.1 Load Center Circuit Breakers .....	16
2.5.2 AC Power Connections .....	17
2.5.3 Neutral Connection .....	18
2.5.4 Neutral Bonding Jumper, Service Entrance Models .....	18
2.5.5 Engine Start Function .....	18
2.5.6 Interface Module Connection .....	19
2.5.7 Optional Load Control Connection .....	20
2.5.8 Accessory Module Connections .....	20
2.6 Test and Exercise .....	20
2.7 Warranty Registration .....	20
<b>Section 3 Operation</b> .....	<b>21</b>
3.1 Model RXT Transfer Switch Operation .....	21
3.2 Source Availability .....	21
3.3 ATS Control Sequence of Operation .....	21
3.4 Time Delays .....	22
3.5 Load Control Time Delay .....	22
<b>Section 4 Service Disconnect, SE Model</b> .....	<b>23</b>
4.1 Service Disconnect Procedure .....	23
4.2 Source Circuit Breaker Reset .....	23
<b>Section 5 Scheduled Maintenance</b> .....	<b>25</b>
5.1 Introduction .....	25
5.2 Testing .....	26
5.2.1 Weekly Generator Set Exercise .....	26
5.2.2 Monthly Automatic Control System Test .....	26

# Table of Contents, continued

---

5.3	Inspection and Service .....	26
5.3.1	General Inspection .....	26
5.3.2	Other Inspections and Service .....	27
5.4	Service Schedule .....	27
<b>Section 6 Diagrams and Drawings .....</b>		<b>29</b>
Appendix A	Abbreviations .....	55

# Safety Precautions and Instructions

IMPORTANT SAFETY INSTRUCTIONS. Electromechanical equipment, including generator sets, transfer switches, switchgear, and accessories, can cause bodily harm and pose life-threatening danger when improperly installed, operated, or maintained. To prevent accidents be aware of potential dangers and act safely. Read and follow all safety precautions and instructions. **SAVE THESE INSTRUCTIONS.**

This manual has several types of safety precautions and instructions: Danger, Warning, Caution, and Notice.

## DANGER

Danger indicates the presence of a hazard that **will cause severe personal injury, death, or substantial property damage.**

## WARNING

Warning indicates the presence of a hazard that **can cause severe personal injury, death, or substantial property damage.**

## CAUTION

Caution indicates the presence of a hazard that **will or can cause minor personal injury or property damage.**

## NOTICE

Notice communicates installation, operation, or maintenance information that is safety related but not hazard related.

Safety decals affixed to the equipment in prominent places alert the operator or service technician to potential hazards and explain how to act safely. The decals are shown throughout this publication to improve operator recognition. Replace missing or damaged decals.

## Accidental Starting

### WARNING



**Accidental starting.  
Can cause severe injury or death.**

Disconnect the battery cables before working on the generator set. Remove the negative (-) lead first when disconnecting the battery. Reconnect the negative (-) lead last when reconnecting the battery.

**Disabling the generator set. Accidental starting can cause severe injury or death.** Before working on the generator set or connected equipment, disable the generator set as follows: (1) Move the generator set master switch to the OFF position. (2) Disconnect the power to the battery charger. (3) Remove the battery cables, negative (-) lead first. Reconnect the negative (-) lead last when reconnecting the battery. Follow these precautions to prevent starting of the generator set by an automatic transfer switch, remote start/stop switch, or engine start command from a remote computer.

## Hazardous Voltage/ Moving Parts

### DANGER



**Hazardous voltage.  
Will cause severe injury or death.**

Disconnect all power sources before opening the enclosure.

### DANGER



**Hazardous voltage.  
Will cause severe injury or death.**

Only authorized personnel should open the enclosure.

### DANGER



**Hazardous voltage.  
Will cause severe injury or death.**

This equipment must be installed and serviced by qualified electrical personnel.



**Grounding electrical equipment. Hazardous voltage can cause severe injury or death.** Electrocution is possible whenever electricity is present. Ensure you comply with all applicable codes and standards. Electrically ground the generator set, transfer switch, and related equipment and electrical circuits. Turn off the main circuit breakers of all power sources before servicing the equipment. Never contact electrical leads or appliances when standing in water or on wet ground because these conditions increase the risk of electrocution.

**Short circuits. Hazardous voltage/current can cause severe injury or death.** Short circuits can cause bodily injury and/or equipment damage. Do not contact electrical connections with tools or jewelry while making adjustments or repairs. Remove all jewelry before servicing the equipment.

**Making line or auxiliary connections. Hazardous voltage can cause severe injury or death.** To prevent electrical shock deenergize the normal power source before making any line or auxiliary connections.

**Servicing the transfer switch. Hazardous voltage can cause severe injury or death.** Deenergize all power sources before servicing. Turn off the main circuit breakers of all transfer switch power sources and disable all generator sets as follows: (1) Move all generator set master controller switches to the OFF position. (2) Disconnect power to all battery chargers. (3) Disconnect all battery cables, negative (-) leads first. Reconnect negative (-) leads last when reconnecting the battery cables after servicing. Follow these precautions to prevent the starting of generator sets by an automatic transfer switch, remote start/stop switch, or engine start command from a remote computer. Before servicing any components inside the enclosure: (1) Remove all jewelry. (2) Stand on a dry, approved electrically insulated mat. (3) Test circuits with a voltmeter to verify that they are deenergized.

## Heavy Equipment

 <b>WARNING</b>

<p><b>Unbalanced weight. Improper lifting can cause severe injury or death and equipment damage.</b></p> <p>Use adequate lifting capacity. Never leave the transfer switch standing upright unless it is securely bolted in place or stabilized.</p>

## Notice

### NOTICE

**Foreign material contamination.** Cover the transfer switch during installation to keep dirt, grit, metal drill chips, and other debris out of the components. Cover the solenoid mechanism during installation. After installation, use the manual operating handle to cycle the contactor to verify that it operates freely. Do not use a screwdriver to force the contactor mechanism.

### NOTICE

**Electrostatic discharge damage.** Electrostatic discharge (ESD) damages electronic circuit boards. Prevent electrostatic discharge damage by wearing an approved grounding wrist strap when handling electronic circuit boards or integrated circuits. An approved grounding wrist strap provides a high resistance (about 1 megohm), *not a direct short*, to ground.

This manual provides operation and installation instructions for Kohler® Model RXT automatic transfer switches. See Figure 1 for typical Model RXT transfer switches.

Model RXT transfer switches operate only with Kohler® Model generator sets equipped with the RDC2 or DC2 generator/transfer switch controller. See Figure 2 for controller identification. The following Kohler® model generator sets can be used with the Model RXT transfer switch:

- 14RESA
- 14RESAL
- 20RESA
- 20RESAL
- 48RCL

Information in this publication represents data available at the time of print. Kohler Co. reserves the right to change this literature and the products represented without notice and without any obligation or liability whatsoever.

Read this manual and carefully follow all procedures and safety precautions to ensure proper equipment operation and to avoid bodily injury. Read and follow the Safety Precautions and Instructions section at the beginning of this manual. Keep this manual with the equipment for future reference.

The equipment service requirements are very important to safe and efficient operation. Inspect parts often and perform required service at the prescribed intervals. Obtain service from an authorized service distributor/dealer to keep equipment in top condition.



**Figure 1** Typical Model RXT Transfer Switches (shown with optional status indicators)

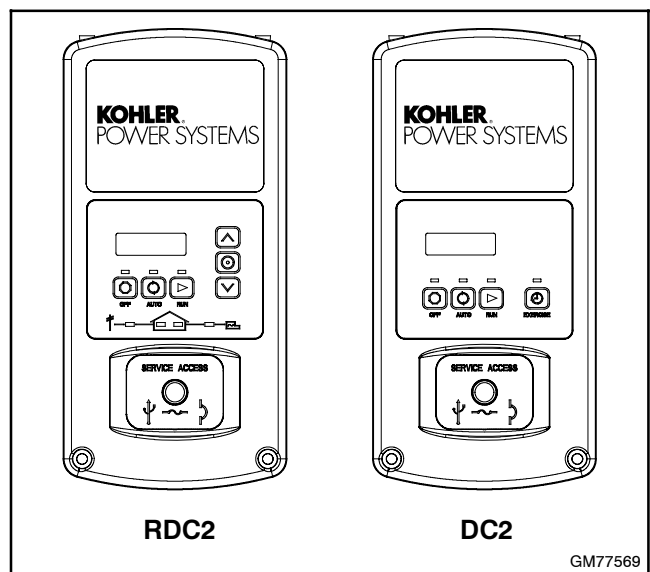

**Figure 2** RDC2 and DC2 Generator/Transfer Switch Controllers (provided with and mounted on the generator set)

## Nameplate

A nameplate attached to the inside of the enclosure cover or on the upper right side wall includes a model designation, a serial number, ratings, and other information about the transfer switch. See Figure 3.

Check the transfer switch model number from the transfer switch nameplate and verify that it matches the model shown on the front cover of this manual before proceeding with installation.

Copy the model designation, serial number, and accessory information from the nameplate to the spaces provided in the Product Identification Information section located inside the front cover of this manual for use when requesting service or parts.

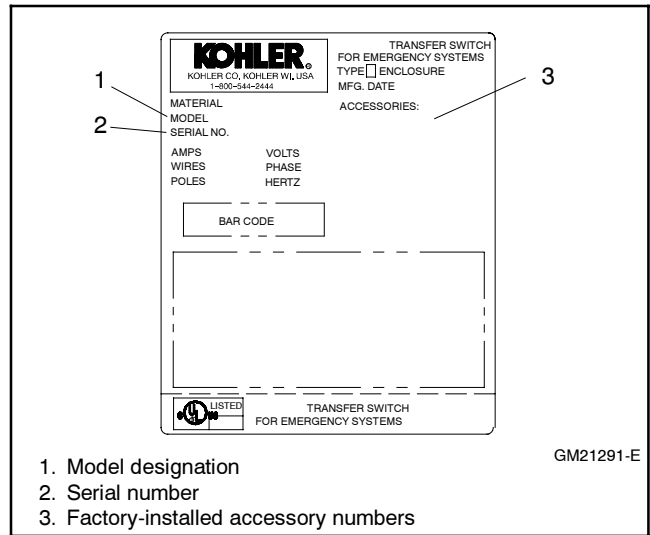

**Figure 3** Typical Transfer Switch Nameplate

## Model Designation

Figure 4 explains the model designation.

**Record the transfer switch model designation in the boxes. The transfer switch model designation defines ratings and characteristics as explained below.**

**Sample Model Designation: RXT-JFNC-0200A**

<p><b>Model</b> RXT: Kohler Automatic Transfer Switch</p> <p><b>Controls</b> J: Interface for RDC2/DC2 Controller</p> <p><b>Voltage/Frequency</b> C: 208 Volts/60 Hz (3-phase only) F: 240 Volts/60 Hz M: 480 Volts/60 Hz (3-phase only)</p> <p><b>Number of Poles/Wires</b> N: 2-pole, 3-wire, solid neutral (120/240 V only) T: 3-pole, 4-wire, solid neutral V: 4-pole, 4-wire, switched neutral</p>	<p><b>Enclosure</b> C: NEMA 3R</p> <p><b>Current Rating:</b> Numbers indicate the current rating of the switch in amperes: 0100 0200 0400</p> <p><b>Connections</b> A: No load center B: With load center (100 amp single-phase only) ASE: Service entrance rated</p>
---	---

**Figure 4** Model Designation



For professional advice on generator set power requirements and conscientious service, please contact your nearest Kohler distributor or dealer.

- Consult the Yellow Pages under the heading Generators—Electric.
- Visit the Kohler Power Systems website at KohlerPower.com.
- Look at the labels and stickers on your Kohler product or review the appropriate literature or documents included with the product.
- Call toll free in the US and Canada 1-800-544-2444.
- Outside the US and Canada, call the nearest regional office.

## **Headquarters Europe, Middle East, Africa (EMEA)**

Kohler Power Systems  
3 rue de Brennus  
93200 Saint Denis  
France  
Phone: (33) 1 49 178300  
Fax: (33) 1 49 178301

## **Asia Pacific**

Power Systems Asia Pacific Regional Office  
Singapore, Republic of Singapore  
Phone: (65) 6264-6422  
Fax: (65) 6264-6455

## **China**

North China Regional Office, Beijing  
Phone: (86) 10 6518 7950  
(86) 10 6518 7951  
(86) 10 6518 7952  
Fax: (86) 10 6518 7955

East China Regional Office, Shanghai  
Phone: (86) 21 6288 0500  
Fax: (86) 21 6288 0550

## **India, Bangladesh, Sri Lanka**

India Regional Office  
Bangalore, India  
Phone: (91) 80 3366208  
(91) 80 3366231  
Fax: (91) 80 3315972

## **Japan, Korea**

North Asia Regional Office  
Tokyo, Japan  
Phone: (813) 3440-4515  
Fax: (813) 3440-2727

## **Latin America**

Latin America Regional Office  
Lakeland, Florida, USA  
Phone: (863) 619-7568  
Fax: (863) 701-7131

# Notes

## 1.1 Transfer Switch Description

An automatic transfer switch (ATS) transfers electrical loads from a normal source of electrical power to an emergency source when the normal source voltage or frequency falls below an acceptable level. The normal source is typically utility power. The emergency source is usually a generator set.

Model RXT transfer switches must be connected to a generator set equipped with the Kohler® RDC2 or DC2 generator/transfer switch controller. Applicable generator set models are listed in the Introduction.

Voltage sensing data from the ATS is continuously transmitted to the RDC2/DC2 controller mounted on the generator set. When the normal source fails, the RDC2/DC2 controller signals the emergency source generator set to start. When the emergency source reaches acceptable levels and stabilizes, the ATS transfers the electrical load to the emergency source.

The RDC2/DC2 controller signals the ATS to transfer the load back when the normal source returns and stabilizes.

Figure 1-1 shows a typical installation block diagram.

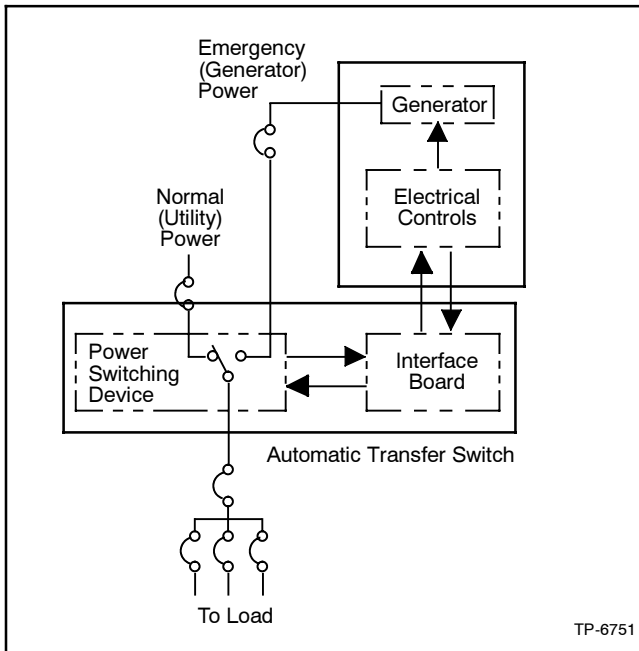

**Figure 1-1** Typical ATS Block Diagram



**Figure 1-2** Selected Transfer Switches (covers removed)

## 1.2 Service Entrance Models

Service entrance models use a circuit breaker to provide the service disconnect for the utility source. A service entrance model is shown in Figure 1-2.

## 1.3 Load Centers

Model RXT 100 amp transfer switches are available with a built-in load center. A model with a built-in load center is shown in Figure 1-2. Models without load centers require the installation of a separate load panel.

**Loads.** The transfer switch can be connected to supply all of the electrical loads in the home, or only the essential loads such as the furnace, refrigerator, well pump, and selected light circuits. Identify the essential circuits that must be supplied during a power outage. Verify that the generator set and transfer switch are adequately rated to supply all of the selected loads.

**Circuit breakers.** Because the size and number of circuit breakers required will vary with each application, circuit breakers are not provided with the transfer switch load center.

Determine the circuits that will be connected to the transfer switch (essential loads). Identify the breakers for those circuits in the main distribution panel.

The ATS load center requires Square D type QO breakers. If the main distribution panel uses the same type of breakers, the breakers can be moved from the main panel to the load center. Otherwise, obtain new Square D type QO circuit breakers. For each circuit, the rating of the load center circuit breaker must match the rating of the existing breaker in the main panel.

Up to 8 tandem breakers can be used. Use Square D type QOT tandem breakers.

Verify that the total rating for all of the breakers used in the load center does not exceed the rating of the transfer switch.

## 1.4 Controller Interface Board

All ATS control functions are performed by the RDC2/DC2 controller mounted on the generator set and communicated through the interface board. The controller interface board sends voltage sensing data to the RDC2/DC2 controller and receives transfer and load control signals from the RDC2/DC2 controller.

## 1.5 Optional LED Indicator Panel

A user interface panel that contains status-indicating LEDs is available. See Figure 1-3. Source available LEDs light to indicate that the utility and/or generator sources are available. The utility or generator source supplying load LED lights to show which source is connected to the building load (i.e. contactor position, normal or emergency).

If the status indicator is purchased as a loose kit (not factory-installed), refer to the installation instructions provided with the kit, TT-1585.

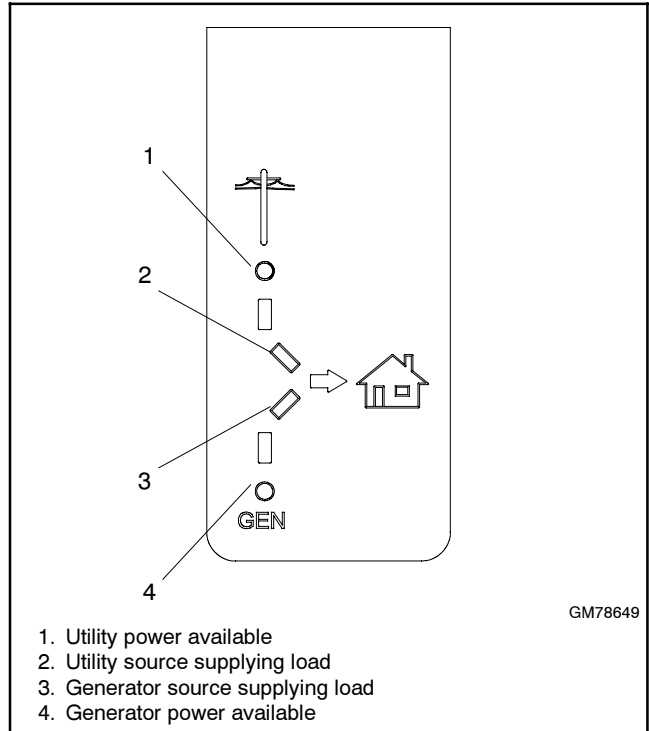

**Figure 1-3** LED Indicators

## 2.1 Introduction

Kohler® transfer switches are shipped factory-wired, factory-tested, and ready for installation. Have the equipment installed only by trained and qualified personnel, and verify that the installation complies with applicable codes and standards. Protect the switch against damage before and during installation.

## 2.2 Receipt of Unit

### 2.2.1 Inspection

At the time of delivery, inspect the packaging and the transfer switch for signs of shipping damage. Unpack the transfer switch as soon as possible and inspect the exterior and interior for shipping damage. If damage and/or rough handling is evident, immediately file a damage claim with the transportation company.

### 2.2.2 Storage

Store the transfer switch in its protective packing until final installation. Protect the transfer switch at all times from moisture, construction grit, and metal chips. Avoid storage in cold or damp areas where moisture could condense on the unit. See Figure 2-1 for acceptable storage temperatures.

Item	Specification
Storage Temperature	-40°C to 85°C (-40°F to 185°F)
Operating Temperature	-20°C to 70°C (-4°F to 158°F)
Humidity	5% to 95% noncondensing
Altitude	0 to 3050 m (10000 ft.) without derating

**Figure 2-1** Environmental Specifications

### 2.2.3 Unpacking

Allow the equipment to warm to room temperature for at least 24 hours before unpacking to prevent condensation on the electrical apparatus. Use care when unpacking to avoid damaging transfer switch components. Use a vacuum cleaner or a dry cloth to remove dirt and packing material that may have

accumulated in the transfer switch or any of its components.

**Note:** Do not use compressed air to clean the switch. Cleaning with compressed air can cause debris to lodge in the components and damage the switch.

### 2.2.4 Lifting

**⚠ WARNING**



**Unbalanced weight. Improper lifting can cause severe injury or death and equipment damage.**

Use adequate lifting capacity.  
Never leave the transfer switch standing upright unless it is securely bolted in place or stabilized.

See Figure 2-2 or the dimensional drawing for the weight of the transfer switch. Use a spreader bar to lift the transfer switch. Attach the bar only to the enclosure's mounting holes or lifting brackets; do not lift the unit any other way. Close and latch the enclosure door before moving the unit.

Amps	Description	Weight, kg (lb.) †
100	Single phase	7 (14)
	With load center	8.2 (18)
	Three phase	14 (30)
	Service Entrance	10 (22)
200	Single phase	7 (15)
	Three phase	14 (30)
	Service Entrance	12 (26)
400	Single phase	36 (80)
	3-Pole/208-240 Volts	41 (90)
	3-Pole/480 Volts	59 (130)
	4-Pole	59 (130)
	Service Entrance	46 (100)

**Figure 2-2** Approximate Weights

## 2.3 Installation

### NOTICE

**Foreign material contamination.** Cover the transfer switch during installation to keep dirt, grit, metal drill chips, and other debris out of the components. Cover the solenoid mechanism during installation. After installation, use the manual operating handle to cycle the contactor to verify that it operates freely. Do not use a screwdriver to force the contactor mechanism.

### NOTICE

**Hardware damage.** The transfer switch may use both American Standard and metric hardware. Use the correct size tools to prevent rounding of the bolt heads and nuts.

**Check the system voltage and frequency.** Compare the voltage and frequency shown on the transfer switch nameplate to the source voltage and frequency. Do not install the transfer switch if the voltage and frequency are different from the normal (utility) source voltage and frequency or the emergency source voltage and frequency shown on the generator set nameplate.

**Plan the installation.** Use the dimensions given on the enclosure dimension (ADV) drawings in Section 6. Select a mounting site that complies with local electrical code restrictions for the enclosure type. Mount the transfer switch as close to the load and power sources as possible. Allow adequate space to open the enclosure and service the switch.

**NEMA 3R enclosures.** To remove the enclosure's front panel, support the panel while removing the screws.

Pull the bottom of the panel out and down until the top clears the enclosure. Remove the inner panel to access the transfer switch components.

NEMA 3R enclosures have locking tabs at the bottom of the enclosure and the door. While the enclosure is open, turn the locking tab out so that the door can be locked with a padlock after installation is complete.

**Wall mounting.** Mount the transfer switch to a wall or other rigid vertical supporting structure. Refer to the dimension drawings in Section 6 for hole locations. Use shims to plumb the enclosure.

Cover or remove the transfer switch's internal components to protect them from drill chips or debris during installation. Use a vacuum cleaner to remove debris from the enclosure.

**Note:** Do not use compressed air to clean the switch. Cleaning with compressed air can cause debris to lodge in the components and cause damage.

Tighten the mounting screws to 2.9 Nm (26 in. lb.) when reinstalling the components.

Clearance holes through the back of each enclosure are provided for mounting. The mounting holes on NEMA 3R enclosures have gaskets to seal out moisture. Use washers with the mounting screws to protect the gaskets.

## 2.4 Manual Operation Check

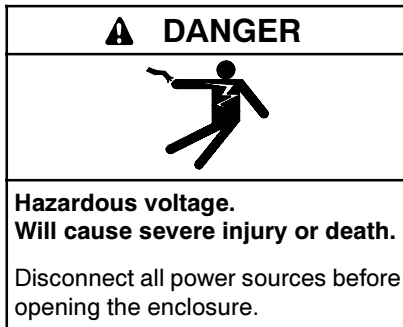

Check the manual operation before energizing the transfer switch. Verify that the contactor operates smoothly without binding. Do not place the transfer switch into service if the contactor does not operate smoothly.

After checking the manual operation, place the contactor in the Normal (utility) position.

See Figure 2-3 to identify the manual operation procedure for your transfer switch.

ATS	Procedure	Figure
100-200 amps, 1-phase	2.4.1	Figure 2-4
100-200 amps, 3-phase	2.4.2	Figure 2-6
400 amps, 1-phase	2.4.1	Figure 2-5
400 amps, 3-phase, 3-pole, 208-240 Volts	2.4.1	Figure 2-5
400 amps, 3-phase, 3-pole/480 Volt and 4-pole	2.4.2	Figure 2-7

**Figure 2-3** Manual Operation Procedure Guide

### 2.4.1 Manual Operation Procedure 1

**Note:** Never manually operate the transfer switch when the power is connected. Disconnect both power sources before manually operating the switch.

- 100-200 amp switches: These switches have an attached handle as shown in Figure 2-4.  
400 amp switches: Slide the detachable handle or a wrench over the shaft. See Figure 2-5.
- Move the handle up to place the transfer switch in the Normal Source position or down to place the contactor in the Emergency Source position. See Figure 2-4 or Figure 2-5.
- 400 amp switches: Remove the detachable handle or wrench.

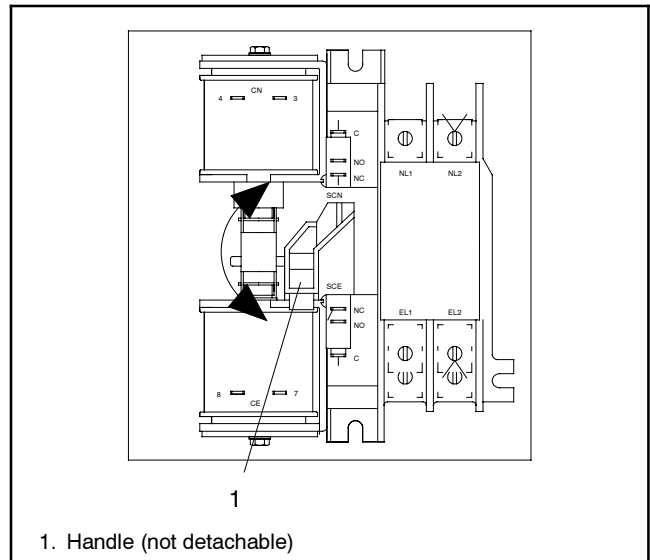

**Figure 2-4** Manual Operation, 100 and 200 Amp Single-Phase Switches

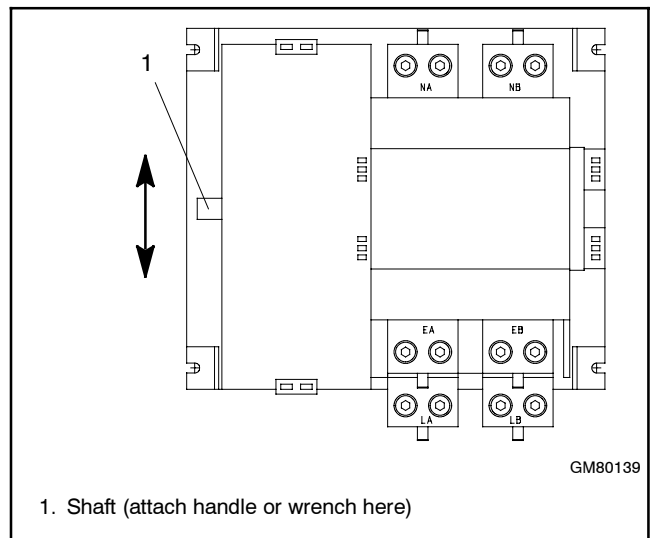

**Figure 2-5** Manual Operation, 400 Amp Single-Phase and 208-240 Volt Switches

### 2.4.2 Manual Operation Procedure 2

**Note:** Never use the maintenance handle to transfer the load with the power connected. Disconnect both power sources before manually operating the switch.

- If the transfer switch is equipped with a maintenance handle, remove the handle from its storage location inside the enclosure. See Figure 2-7.

2. Insert the maintenance handle or a tool (such as a screwdriver) into the hole in the shaft on the left side of the operator as shown in Figure 2-6 or Figure 2-7.
3. Move the maintenance handle (or tool) up or down as shown to manually operate the transfer switch. It should operate smoothly without any binding. If it does not, check for shipping damage or construction debris.
4. Return the transfer switch to the Normal position.
5. Remove the maintenance handle and return it to the storage location.

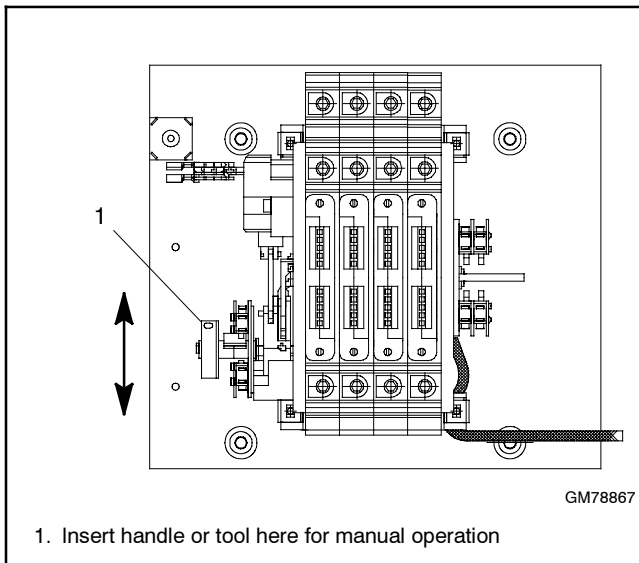

**Figure 2-6** Manual Operation, 100-200 Amp 3-Phase Switches

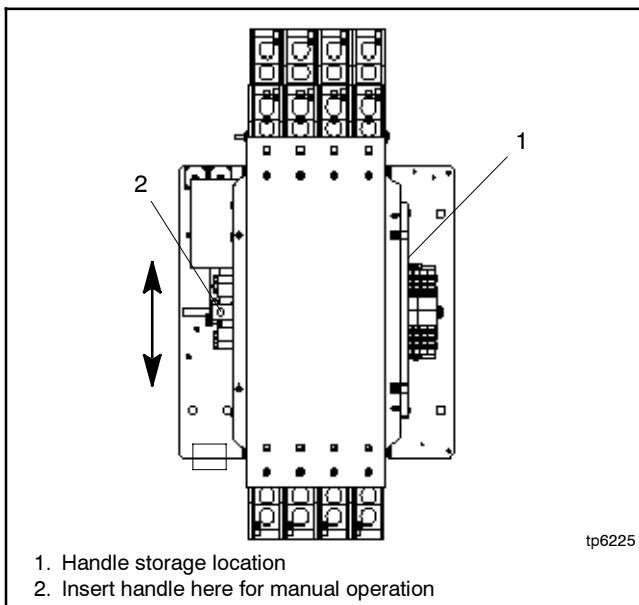
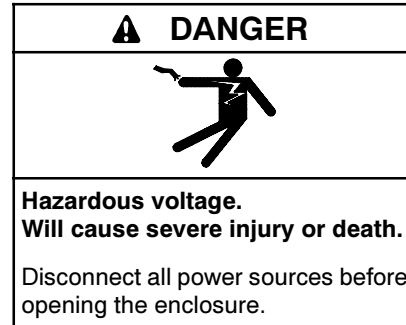

**Figure 2-7** Manual Operation, 400 Amp 3-Phase Switches

## 2.5 Electrical Wiring

Refer to the connection diagrams on the transfer switch enclosure door and the wiring diagrams in Section 6 during installation.

All wiring must comply with applicable national, state, and local electrical codes. Use separate conduit for AC power wiring and low-voltage DC, control, and communication system wiring.



**Making line or auxiliary connections. Hazardous voltage can cause severe injury or death.** To prevent electrical shock deenergize the normal power source before making any line or auxiliary connections.

**Grounding electrical equipment. Hazardous voltage can cause severe injury or death.** Electrocutation is possible whenever electricity is present. Ensure you comply with all applicable codes and standards. Electrically ground the generator set and related equipment and electrical circuits. Turn off the main circuit breakers of all power sources before servicing the equipment. Never contact electrical leads or appliances when standing in water or on wet ground because these conditions increase the risk of electrocution.

### 2.5.1 Load Center Circuit Breakers

The 100 amp Model RXT transfer switch is available with a built-in load center with room for up to 16 single-pole circuit breakers. Up to 8 tandem breakers can be used for a maximum of 24 circuits.

The load center uses Square D type QO or QOT tandem breakers. In an essential load application, the breakers can be moved from the main panel to the load center if the main distribution panel uses the same type of breakers. Otherwise, obtain and install new Square D type QO circuit breakers. The rating of the load center circuit breaker must match the rating of the existing breaker in the main panel for each circuit. If circuit breakers are removed from the load panel, install cover plates over the vacant positions. Cover plates can be obtained from a local Square D supplier.

Verify that the total rating for all breakers used in the load center does not exceed the rating of the transfer switch.



## 2.5.2 AC Power Connections

**Determine the cable size.** Refer to Figure 2-8 or the ADV drawings in Section 6 to determine the cable size required for the transfer switch. Make sure the lugs provided are suitable for use with the cables being installed.

**Conduit.** Use separate conduit for AC power wiring and low-voltage DC, control, and communication system wiring. Watertight conduit hubs may be required for outdoor use.

Select the proper cable clamp or use other approved methods for securing the cable or conduit to the enclosure.

**Source and load connections.** Clean cables with a wire brush to remove surface oxides before connecting them to the terminals. Apply joint compound to the connections of any aluminum conductors.

Refer to the connection diagrams on the transfer switch enclosure door and the wiring diagrams in Section 6. The connection points on the transfer switch contactor are labelled Normal, Emergency, and Load. Connect the utility power to Normal. Connect the generator set to Emergency.

**Single phase.** For single-phase models, connect to A and C.

**Three phase.** For three-phase models, be sure to follow the phase markings (A, B, C, and N).

**Note:** Connect the source and load phases as indicated by the markings and drawings to prevent short circuits and to prevent phase-sensitive devices from malfunctioning or operating in reverse.

**Service entrance models.** Connect the utility source to the lugs on the normal source disconnect circuit breakers as shown in the service entrance switch wiring diagram in Section 6.

Verify that all connections are consistent with drawings before tightening the lugs. Tighten all cable lug connections to the torque values shown on the label on the switch. Carefully wipe off any excess joint compound after tightening the terminal lugs.

On models with built-in load centers, the load lugs are factory-wired to the load center. Connect the load leads to the circuits in the load center and tighten the connections. Check the labels on the breakers for the tightening torques.

### 2.5.3 Neutral Connection

Connect the neutral from the main panel to the neutral lug in the ATS enclosure.

Ground the system according to NEC and local codes.

### 2.5.5 Engine Start Function

The engine start function is controlled by the RDC2/DC2 controller on the generator set. There are no engine start terminals on the Model RXT ATS.

### 2.5.4 Neutral Bonding Jumper, Service Entrance Models

The transfer switch is shipped with the neutral-to-ground jumper installed. For non-service entrance applications, disconnect the neutral-to-ground bonding jumper. See the transfer switch dimension drawing.

Cable Sizes						
AL/CU UL-Listed Solderless Screw-Type Terminals for External Power Connections						
Switch Size, Amps	Switch	Phases	Range of Wire Sizes, Cu/Al			
			Normal and Emergency	Load	Neutral	Ground
100	Standard	1	(1) #14 - 1/0 AWG	(1) #14 - 1/0 AWG	(3) #12 - 1/0 AWG	(9) #4 - 14 AWG
	With load center	1	(1) #14 - 1/0 AWG	per customer-supplied circuit breaker	(1) #2 - 2/0 AWG	(9) #4 - 14 AWG
	Service Entrance	1	Normal: (1) #12 - 2/0 AWG Emerg: (1) #6 - 250 MCM	(1) #6 - 250 MCM	(3) #6 - 250 MCM	(3) #14 - 1/0 AWG
	3-Phase	3	(1) #8 - 3/0 AWG	(1) #8 - 3/0 AWG	(3) #6 AWG - 3/0 AWG	(3) #6 - 3/0 AWG
200	Standard	1	(1) #6 AWG - 250 MCM	(1) #6 AWG - 250 MCM	(3) #6 AWG - 250 MCM	(9) #4 - 14 AWG
	Service Entrance	1	Normal: (1) #4 - 300 MCM Emerg: (1) #6 - 250 MCM	(1) #6 AWG - 250 MCM	(3) #6 AWG - 250 MCM	(3) #14 - 1/0 AWG
	3-Phase	3	(1) #6 AWG - 250 MCM	(1) #6 AWG - 250 MCM	(3) #4 AWG - 600 MCM (6) 1/0 - 250 MCM	(3) #6 - 3/0 AWG
400	Standard	1	(2) #6 - 250 MCM	(2) #6 - 250 MCM	(1) #4 - 600 MCM (2) 1/0 - 250 MCM	(3) #14 - 1/0 AWG
	Service Entrance	1	Normal: (2) 3/0 - 250 MCM Emerg: (2) #6 - 250 MCM	(2) #6 - 250 MCM	(3) #4 - 600 MCM (6) 1/0 - 250 MCM	
	3-pole 208-240 V	3	(2) #6 - 250 MCM	(2) #6 - 250 MCM	(1) #4 - 600 MCM (2) 1/0 - 250 MCM	
	3 or 4 pole 480 V	3	(1) #4 - 600 MCM (2) #6 - 250 MCM	(1) #4 - 600 MCM (2) #6 - 250 MCM	(1) #4 - 600 MCM (2) 1/0 - 250 MCM	

Figure 2-8 Cable Sizes

## 2.5.6 Interface Module Connection

The interface module must be connected to a Kohler® generator set equipped with the RDC2 or DC2 controller. The generator set is typically equipped with a field-connection terminal block. See the generator set Installation Manual for the location of the terminal block.

**Note:** This document gives connection information for one Model RXT transfer switch connected to a generator set equipped with an RDC2 or DC2 controller. If additional accessory modules such as a programmable interface module (PIM) or a load control module (LCM) are connected, refer to the generator set installation manual for cable requirements and connection instructions.

See Figure 2-9 and Figure 2-10. Use 20 AWG Belden #9402, 8723, or equivalent shielded, twisted-pair cable to connect P10-1 through P10-4 on the controller interface module to the generator set terminal block connections A, B, PWR, and COM. The maximum cable length is 61 meters (200 ft.).

Alternatively, 12–14 AWG wire can be used for the PWR and COM connections *only*. If 12–14 AWG wire is used for the PWR and COM connections, the maximum cable length is 152 m (500 ft.) if one Model RXT transfer switch and no accessory modules are connected to the generator set.

**Note:** Connections 3 and 4 on the generator set are not used with the Model RXT transfer switch.

Terminal Block	Connection	Designation	Description	Wire Size
P10	P10-1	A	Communication Line	20 AWG shielded twisted-pair, Belden 9402, 8723, or equivalent
	P10-2	B	Communication Line	
	P10-3	PWR	12 VDC	20 AWG shielded twisted-pair Belden 9402 or 12–14 AWG wire
	P10-4	COM	12 VDC	

**Figure 2-9** Controller Interface Connections

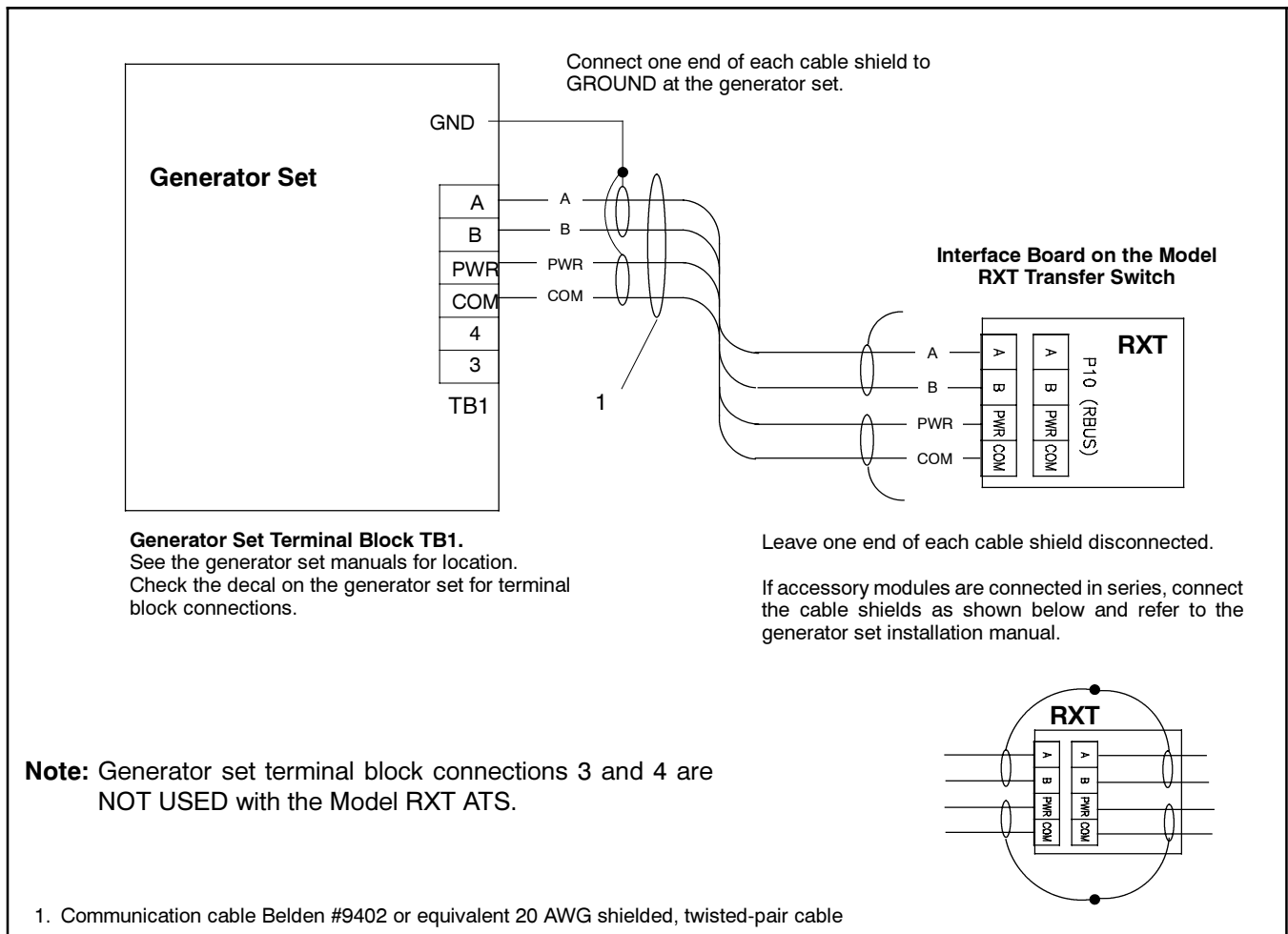

**Figure 2-10** Interface Module Connection to Generator Set Field-Connection Terminal Block

## 2.5.7 Optional Load Control Connection

Connector P11 on the interface module provides a connection point for optional load control circuits. The load control contact provides a delayed contact closure to allow startup of selected loads 5 minutes after transfer to the emergency power source (generator set). Use this contact to delay startup of equipment with large motor-starting loads such as air conditioners.

See Figure 2-11 for the location of load control connector P11. See Figure 2-12 for contact ratings, connection, and wire size information.

**Note:** An optional load control module is available for generator sets equipped with the RDC2 or DC2 controller. The load control module allows management of up to six separate loads (two HVAC thermostat connections and four other non-essential loads). See TT-1574, Load Control Module Instructions.

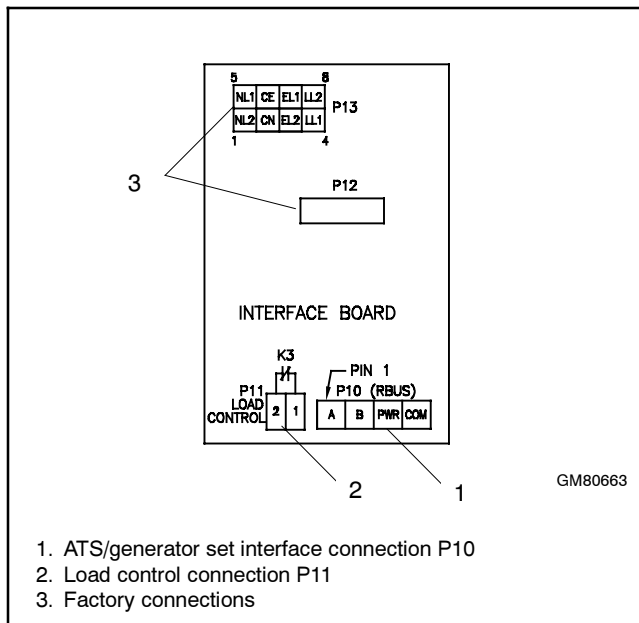

**Figure 2-11** Interface Module Connections

Terminal Block	Connection	Designation	Description	Contact Rating	Wire Size
P11	P11-1	LC1	Load Control Output	10 A @ 250 VAC 1 A @ 30 VDC	#12-18 AWG
	P11-2	LC2			

**Figure 2-12** Load Control Contact P11 Connections

## 2.5.8 Accessory Module Connections

For connection of the optional load control module (LCM) or programmable interface module (PIM), refer to the instructions provided with the modules and to the generator set installation manual.

## 2.6 Test and Exercise

Refer to the generator set Operation Manual for instructions to test the power system operation and to set the RDC2 or DC2 controller for weekly exercise runs to keep the power system in good operating condition.

## 2.7 Warranty Registration

**Startup Notification Form.** The Startup Notification Form covers all equipment in the standby system. Complete the Startup Notification Form and register the equipment in the Kohler online warranty system within 60 days of the initial startup date. Standby systems not registered within 60 days of startup are automatically registered using the manufacturer's ship date as the startup date.

## 3.1 Model RXT Transfer Switch Operation

The Model RXT transfer switch must be connected to a generator set equipped with the RDC2 or DC2 controller. The RDC2/DC2 generator set/transfer switch controller manages automatic transfer switch (ATS) functions when connected to a Kohler® Model RXT transfer switch through the ATS interface board. The controller receives voltage sensing data from the Model RXT ATS and operates the generator set and transfer switch to provide standby power when utility power is lost.

See the generator set operation manual for:

- ATS status screens and configuration menus.
- Information about loaded exercise.

## 3.2 Source Availability

The Model RXT transfer switch supplies voltage sensing data to the RDC2 or DC2 controller through the ATS interface board. If the source voltage falls below the undervoltage dropout setting, the source is considered to have failed. See Figure 3-1.

Voltage Sensing Parameter	Setting
Accuracy	± 5%
Undervoltage Dropout	90% of Pickup
Undervoltage Pickup	90% of Nominal

**Figure 3-1** Voltage Sensing Parameters

## 3.3 ATS Control Sequence of Operation

See Figure 3-2 for time delay settings.

### Preferred Source Fails:

1. The load control contact opens.
2. The engine start time delay times out.
3. The generator set is signaled to start.
4. The generator starts and the emergency source becomes available.
5. The normal-to-emergency time delay times out.
6. The transfer switch transfers to the emergency source.
7. The load control contact time delay times out.
8. The load control contact closes.

### Normal Source Returns:

1. The emergency-to-normal time delay times out.
2. The contactor transfers to the normal source.
3. The engine cooldown time delay times out.
4. The generator is signaled to stop.

### 3.4 Time Delays

Time delays are factory-set to the values shown in Figure 3-2. An authorized distributor/dealer can adjust time delays using a personal computer and Kohler® SiteTech™ software.

Time delays described in this section operate only when the RDC2 or DC2 generator set controller is connected to a Kohler® Model RXT transfer switch.

The engine start and load transfer time delays prevent engine start and load transfer caused by brief variations in the utility power source.

### 3.5 Load Control Time Delay

The load control time delay allows delayed starting of large motor loads (such as air conditioners), preventing simultaneous starting of large motors after transfer to the generator set. The load control time delay is fixed at 5 minutes. It is not adjustable.

The load must be connected to the load control output on the interface board of the Model RXT transfer switch. See the transfer switch operation and installation manual for connection instructions.

**Note:** A separate load control module (LCM) that provides four power relays and two HVAC relays is available for generator sets equipped with the RDC2 or DC2 controller. See LCM Specification Sheet G6-120 for more information.

Time Delay	Setting	Description
Engine Start	3 seconds	Time delay after utility source is lost until the engine start cycle begins. Guards against starting the generator set because of a brief change in the utility source.
Transfer, Normal to Emergency	3 seconds	Time delay after emergency source becomes available until transfer to emergency source.
Transfer, Emergency to Normal	2 minutes	Time delay after the utility source returns until transfer back to normal. Ensures that the utility source is stable before transferring from the emergency source.
Load Control	5 minutes	Allows delayed connection of selected loads to the generator set. Prevents simultaneous starting of large motors after transfer to the emergency source. Recommended for delayed starting of air conditioners.

Figure 3-2 Time Delays

## Section 4 Service Disconnect, SE Model

**Note:** This section applies only to service entrance model transfer switches, which are identified with the letters ASE at the end of the model designation.

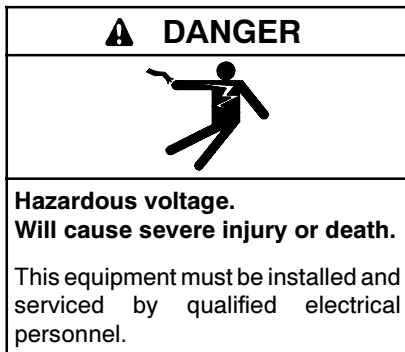

### 4.1 Service Disconnect Procedure

Use the following procedure to disconnect the utility source on service entrance model transfer switches.

**Note:** Power is still present on the input side of the utility source circuit breaker after this procedure.

1. Prevent the emergency generator set from starting:
  - a. Press the OFF button on the generator set controller.
  - b. Disconnect power to the generator set battery charger.
  - c. Disconnect the generator set engine starting battery, negative (-) lead first.
2. On the transfer switch, remove the outer enclosure door only.
3. Move the utility source circuit breaker to the OFF position.

**Note:** Power is still present on the input side of the utility source circuit breaker. Do not remove the protective barrier around the utility source connection lugs.

4. To lock out the transfer switch, replace the outer door and attach a padlock to the hasp.

### 4.2 Source Circuit Breaker Reset

The utility source circuit breaker can trip due to an overcurrent condition. Identify and correct the cause of the overcurrent condition before resetting the circuit breaker. Contact a local distributor/dealer for service if necessary.

When the circuit breaker trips, the handle moves to an intermediate position. To reset a tripped circuit breaker, move the handle to the extreme OFF position and then to the ON position.

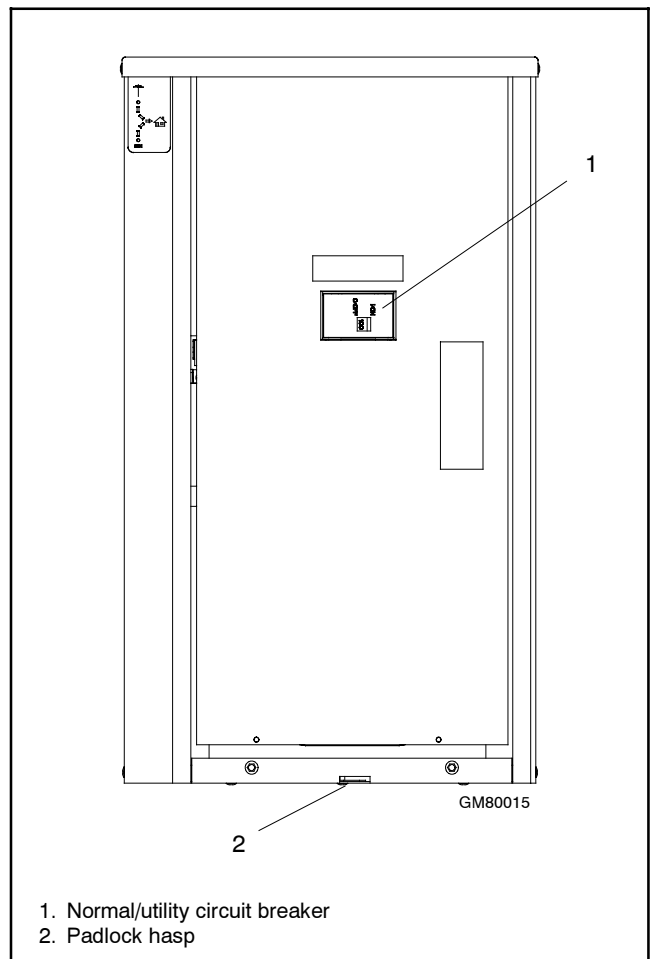

**Figure 4-1** Service Entrance Model, Door Removed

# Notes



## Section 5 Scheduled Maintenance

### 5.1 Introduction

Regular preventive maintenance ensures safe and reliable operation and extends the life of the transfer switch. Preventive maintenance includes periodic testing, cleaning, inspection, and replacement of worn or missing components. Section 5.4 contains a service schedule for recommended maintenance tasks.

A local authorized distributor/dealer can provide complete preventive maintenance and service to keep the transfer switch in top condition. Unless otherwise specified, have maintenance or service performed by an authorized distributor/dealer in accordance with all applicable codes and standards. See the Service Assistance section in this manual for how to locate a local distributor/dealer.

Keep records of all maintenance or service.

Replace all barriers and close and lock the enclosure door after maintenance or service and before reapplying power.

---

**⚠ WARNING**



**Accidental starting. Can cause severe injury or death.**

Disconnect the battery cables before working on the generator set. Remove the negative (-) lead first when disconnecting the battery. Reconnect the negative (-) lead last when reconnecting the battery.

---

**Disabling the generator set. Accidental starting can cause severe injury or death.** Before working on the generator set or connected equipment, disable the generator set as follows: (1) Move the generator set master switch to the OFF position. (2) Disconnect the power to the battery charger. (3) Remove the battery cables, negative (-) lead first. Reconnect the negative (-) lead last when reconnecting the battery. Follow these precautions to prevent starting of the generator set by an automatic transfer switch, remote start/stop switch, or engine start command from a remote computer.

**⚠ DANGER**



**Hazardous voltage. Will cause severe injury or death.**

Disconnect all power sources before opening the enclosure.

**⚠ DANGER**



**Hazardous voltage. Will cause severe injury or death.**

Only authorized personnel should open the enclosure.

**⚠ WARNING**



**Hazardous voltage. Moving parts. Can cause severe injury or death.**

Operate the generator set only when all guards and electrical enclosures are in place.

**Grounding the transfer switch. Hazardous voltage can cause severe injury or death.** Electrocutation is possible whenever electricity is present. Open main circuit breakers of all power sources before servicing equipment. Configure the installation to electrically ground the transfer switch and related equipment and electrical circuits to comply with applicable codes and standards. Never contact electrical leads or appliances when standing in water or on wet ground, as the chance of electrocution increases under such conditions.

**Servicing the transfer switch. Hazardous voltage can cause severe injury or death.** Deenergize all power sources before servicing. Turn off the main circuit breakers of all transfer switch power sources and disable all generator sets as follows: (1) Move all generator set master controller switches to the OFF position. (2) Disconnect power to all battery chargers. (3) Disconnect all battery cables, negative (-) leads first. Reconnect negative (-) leads last when reconnecting the battery cables after servicing. Follow these precautions to prevent the starting of generator sets by an automatic transfer switch, remote start/stop switch, or engine start command from a remote computer. Before servicing any components inside the enclosure: (1) Remove all jewelry. (2) Stand on a dry, approved electrically insulated mat. (3) Test circuits with a voltmeter to verify that they are deenergized.

**Short circuits. Hazardous voltage/current can cause severe injury or death.** Short circuits can cause bodily injury and/or equipment damage. Do not contact electrical connections with tools or jewelry while making adjustments or repairs. Remove all jewelry before servicing the equipment.

#### NOTICE

**Hardware damage.** The transfer switch may use both American Standard and metric hardware. Use the correct size tools to prevent rounding of the bolt heads and nuts.

#### NOTICE

**Electrostatic discharge damage.** Electrostatic discharge (ESD) damages electronic circuit boards. Prevent electrostatic discharge damage by wearing an approved grounding wrist strap when handling electronic circuit boards or integrated circuits. An approved grounding wrist strap provides a high resistance (about 1 megohm), *not a direct short*, to ground.

Screws and nuts are available in different hardness ratings. To indicate hardness, American Standard hardware uses a series of markings and metric hardware uses a numeric system. Check the markings on the bolt heads and nuts for identification.

## 5.2 Testing

### 5.2.1 Weekly Generator Set Exercise

Use the exerciser or a manual test to start and run the generator set under load once a week to maximize the reliability of the emergency power system.

### 5.2.2 Monthly Automatic Control System Test

Test the transfer switch's automatic control system monthly. Refer to the RDC2/DC2 controller operation manual for the test procedure.

- Verify that the expected sequence of operations occurs as the switch transfers the load to the emergency source when a preferred source failure occurs or is simulated.

- Watch and listen for signs of excessive noise or vibration during operation.
- After the switch transfers the load to the standby source, end the test and verify that the expected sequence of operations occurs as the transfer switch retransfers to the preferred source.

## 5.3 Inspection and Service

Contact an authorized distributor/dealer to inspect and service the transfer switch annually and also when any wear, damage, deterioration, or malfunction of the transfer switch or its components is evident or suspected.

### 5.3.1 General Inspection

**External Inspection.** Keep the transfer switch clean and in good condition by performing a weekly general external inspection of the transfer switch. Check for any condition of vibration, leakage, excessive temperature, contamination, or deterioration. Remove accumulations of dirt, dust, and other contaminants from the transfer switch's external components or enclosure with a vacuum cleaner or by wiping with a dry cloth or brush.

**Note:** Do not use compressed air to clean the transfer switch because it can cause debris to lodge in the components and damage the switch.

Tighten loose external hardware. Replace worn, missing, or broken external components with manufacturer-recommended replacement parts. Contact an authorized distributor/dealer for specific part information and ordering.

**Internal Inspection.** Disconnect all power sources, open the transfer switch enclosure door, and inspect internal components monthly or when any condition noticed during an external inspection may have affected internal components.

Contact an authorized distributor/dealer to inspect and service the transfer switch if any of the following conditions are found inside the transfer switch.

- Accumulations of dirt, dust, moisture, or other contaminants.
- Signs of corrosion.
- Worn, missing, or broken components.
- Loose hardware.
- Wire or cable insulation deterioration, cuts, or abrasion.

- Signs of overheating or loose connections: discoloration of metal, melted plastic, or a burning odor.
- Other evidence of wear, damage, deterioration, or malfunction of the transfer switch or its components.

If the application does not allow a power interruption for the time required for the internal inspection, have an authorized distributor/dealer perform the internal inspection.

### 5.3.2 Other Inspections and Service

Have an authorized distributor/dealer perform scheduled maintenance, service, and other maintenance that ensures the safe and reliable

operation of the transfer switch. See Section 5.4, Service Schedule, for the recommended maintenance items and service intervals.

Have an authorized distributor/dealer repair or replace damaged or worn internal components with manufacturer-recommended replacement parts.

## 5.4 Service Schedule

Follow the service schedule in Figure 5-1 for the recommended service intervals. Have all service performed by an authorized distributor/dealer except for activities designated by an X, which may be performed by the switch operator.

System Component or Procedure	See Section	Visually Inspect	Check	Adjust, Repair, Replace	Clean	Test	Frequency
<b>Electrical System</b>							
Check for signs of overheating or loose connections: discoloration of metal, melted plastic, or a burning odor	5.3.1	X	X				Y
Check the contactor's external operating mechanism for cleanliness; clean and relubricate if dirty *	5.3.1	X			D (clean and lube)		Y
Inspect wiring insulation for deterioration, cuts, or abrasion. Repair or replace deteriorated or damaged wiring	5.3.1	X	D	D			Y
Tighten control and power wiring connections to specifications	2.5		D			D	Y
Check the transfer switch's main power switching contacts' condition; clean or replace the main contacts or replace the contactor assembly as necessary	S/M	D		D	D		Y
<b>General Equipment Condition</b>							
Inspect the outside of the transfer switch for any signs of excessive vibration, leakage, high temperature, contamination, or deterioration *	5.3	X			X		M
Check that all external hardware is in place, tightened, and not badly worn	5.3	X	X	X			M
Inspect the inside of transfer switch for any signs of excessive vibration, leakage, high temperature, contamination, or deterioration *	5.3	D	D		D		Y
Check that all internal hardware is in place, tightened, and not badly worn	5.3	X	D	D			Y
* Service more frequently if the transfer switch is operated in dusty or dirty areas.							
<b>See Section:</b> Read these sections carefully for additional information before attempting maintenance or service.							
<b>Visually Inspect:</b> Examine these items visually.							
<b>Check:</b> Requires physical contact with or movement of system components, or the use of nonvisual indications.							
<b>Adjust, Repair, Replace:</b> Includes tightening hardware and lubricating the mechanism. May require replacement of components depending upon the severity of the problem.							
<b>Clean:</b> Remove accumulations of dirt and contaminants from external transfer switch's components or enclosure with a vacuum cleaner or by wiping with a dry cloth or brush. <i>Do not use compressed air to clean the switch because it can cause debris to lodge in the components and cause damage.</i>							
<b>Test:</b> May require tools, equipment, or training available only through an authorized distributor/dealer.							
<b>Symbols used in the chart:</b>							
X= The transfer switch operator can perform these tasks.				Q=Quarterly			
D=Authorized distributor/dealer must perform these tasks.				S=Semiannually (every six months)			
W=Weekly				Y=Yearly (annually)			
M=Monthly				W/D=Wiring diagram			

Figure 5-1 Service Schedule

# Notes

## Section 6 Diagrams and Drawings

---

Diagram or Drawing	Drawing Number	Page
<b>Single-Phase</b>		
<b>Enclosure Dimension Drawings</b>		
100-200 Amp Single-Phase		
Sheet 1 .....	ADV-8190 1 of 2	30
Sheet 2 .....	ADV-8190 2 of 2	31
100 Amp Single-Phase with Load Center .....	ADV-8197	41
400 Amp Single-Phase .....	ADV-8193	36
<b>Wiring Diagrams</b>		
100-400 Amp Single-Phase .....	GM80663	42
100 Amp Single-Phase with Load Center .....	GM80675	52
<b>Schematic Diagrams</b>		
100-400 Amp Single-Phase .....	GM80664	43
100 Amp Single-Phase with Load Center .....	GM80676	53
<b>Service Entrance</b>		
<b>Enclosure Dimension Drawings</b>		
100-200 Amp Single-Phase Service Entrance		
Sheet 1 .....	ADV-8192 1 of 3	33
Sheet 2 .....	ADV-8192 2 of 3	34
Sheet 3 .....	ADV-8192 3 of 3	35
400 Amp Single-Phase Service Entrance Switch		
Sheet 1 .....	ADV-8196 1 of 2	39
Sheet 2 .....	ADV-8196 2 of 2	40
<b>Wiring Diagrams</b>		
100-400 Amp Service Entrance .....	GM80665	44
<b>Schematic Diagrams</b>		
100-400 Amp Service Entrance .....	GM80666	45
<b>Three-Phase</b>		
<b>Enclosure Dimension Drawings</b>		
100-200 Amp Standard, Three-Phase, 3- and 4-Pole .....	ADV-8191	32
400 Amp Standard, Three-Phase, 3-pole 208-240 V .....	ADV-8194	37
400 Amp Standard, Three-Phase, 4-pole and 3-Pole/480 V .....	ADV-8195	38
<b>Wiring Diagrams</b>		
100-200 Amp Standard, Three-Phase, 3- and 4-Pole .....	GM80667	46
400 Amp Standard, Three-Phase, 3-pole 208-240 V .....	GM80669	48
400 Amp Standard, Three-Phase, 4-pole and 3-Pole/480 V .....	GM80671	50
<b>Schematic Diagrams</b>		
100-200 Amp Standard, Three-Phase, 3- and 4-Pole .....	GM80668	47
400 Amp Standard, Three-Phase, 3-pole 208-240 V .....	GM80670	49
400 Amp Standard, Three-Phase, 4-pole and 3-Pole/480 V .....	GM80672	51

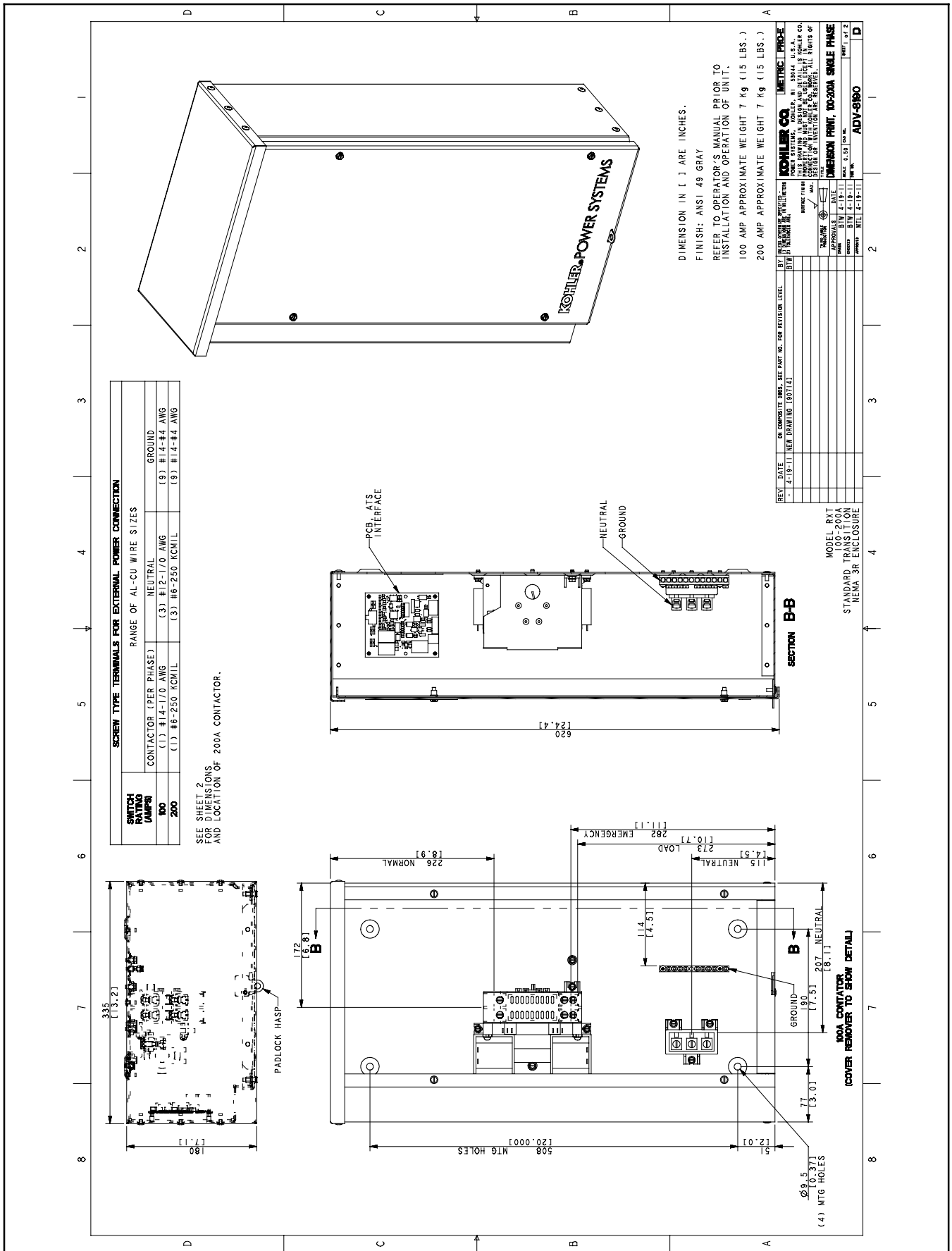

Figure 6-1 Enclosure Dimensions, 100-200 Amp Single-Phase, ADV-8190, Sheet 1 of 2

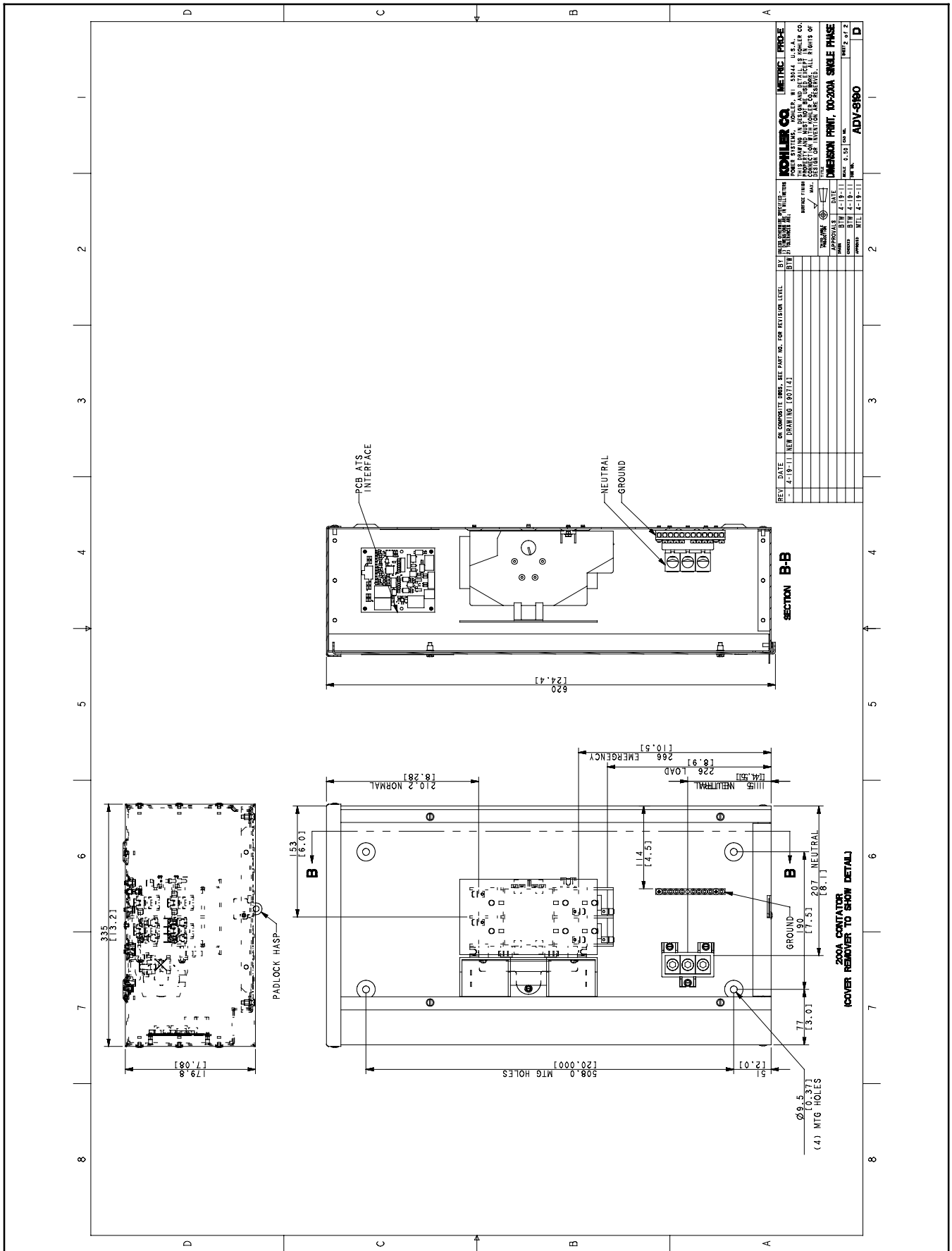
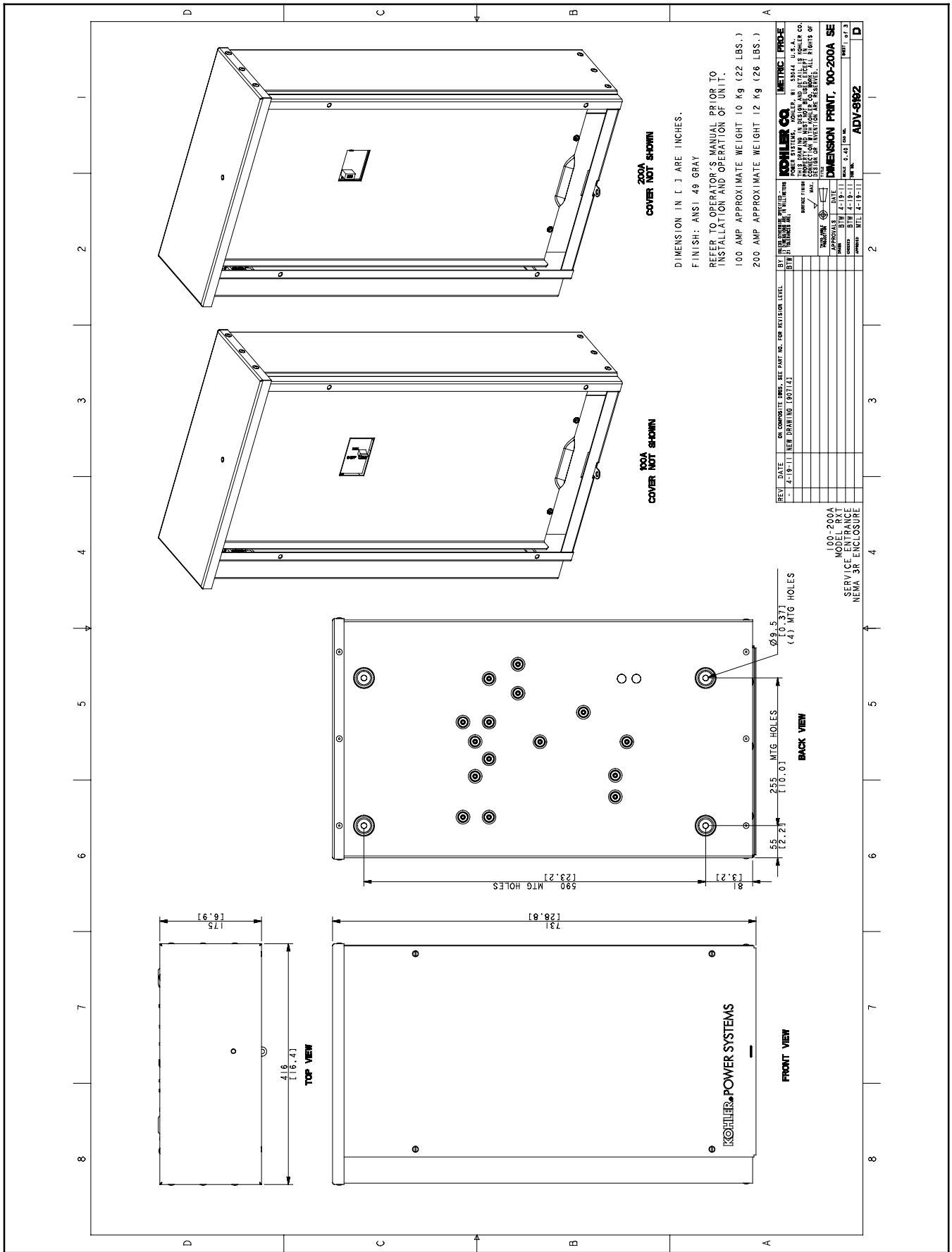

Figure 6-2 Enclosure Dimensions, 100-200 Amp Single-Phase, ADV-8190, Sheet 2 of 2

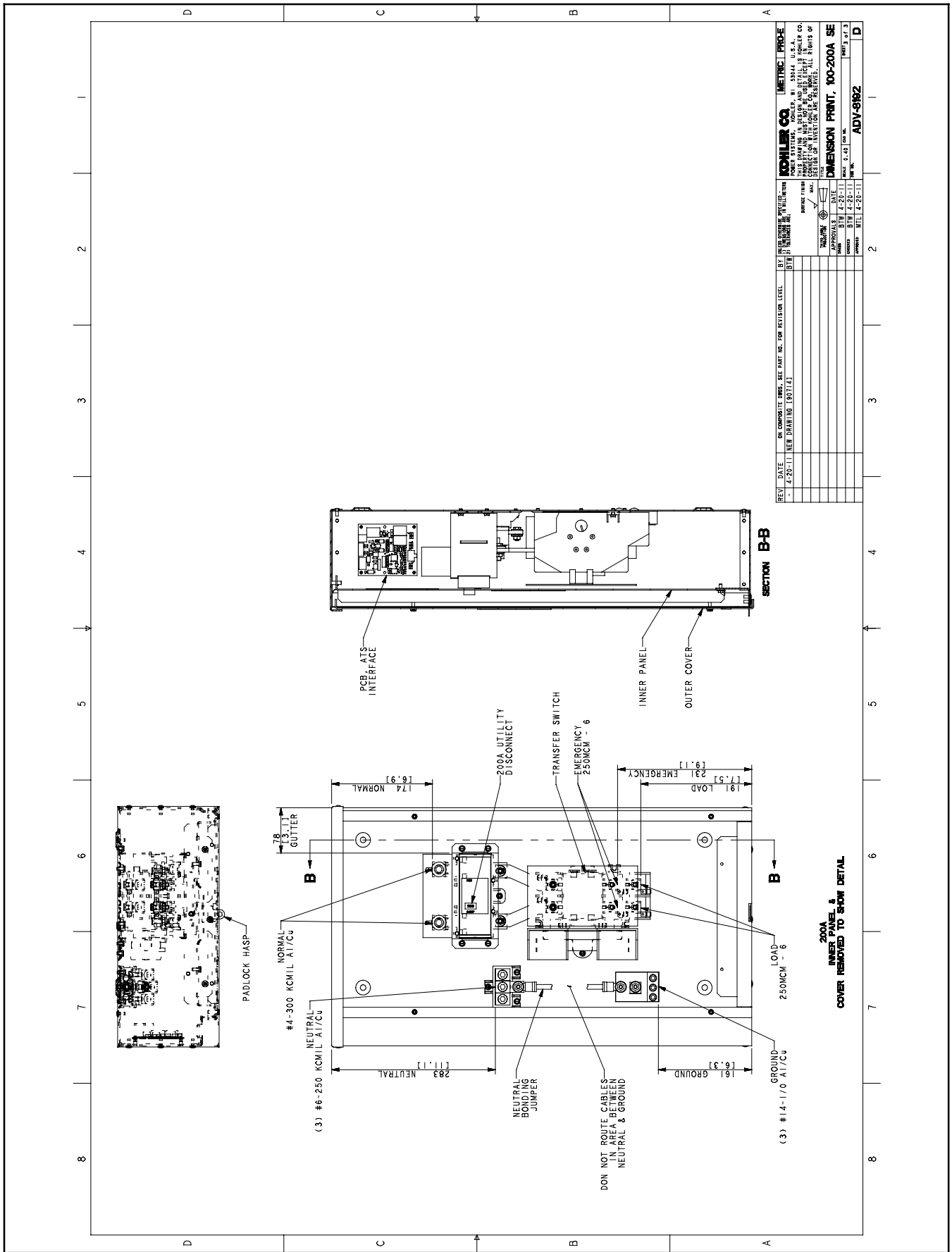





**Figure 6-4** Enclosure Dimensions, 100-200 Amp Single-Phase, Service Entrance, ADV-8192, Sheet 1 of 3





**Figure 6-6** Enclosure Dimensions, 100-200 Amp Single-Phase, Service Entrance, ADV-8192, Sheet 3 of 3









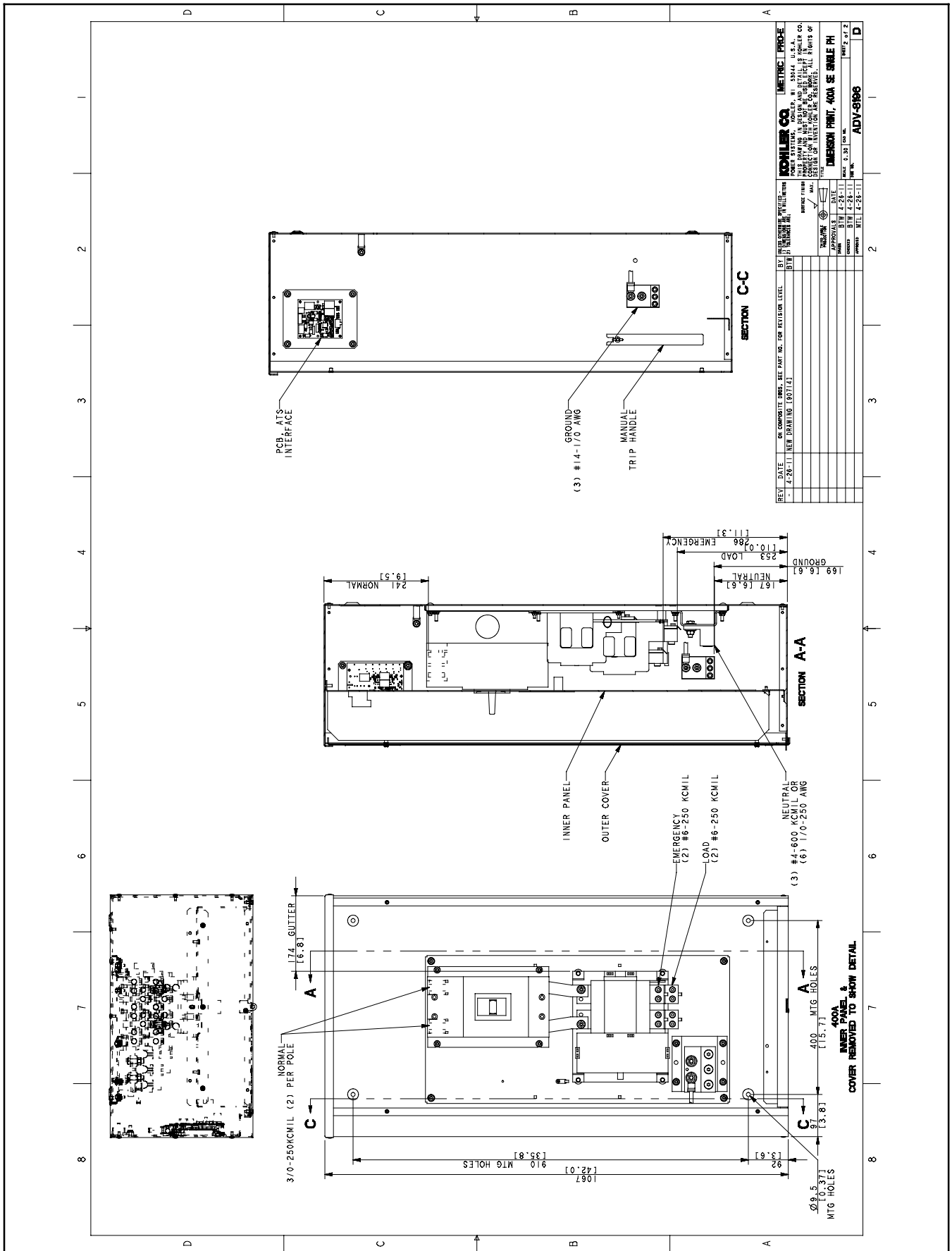

Figure 6-11 Enclosure Dimensions, 400 Amp Single-Phase, Service Entrance, ADV-8196, Sheet 2 of 2



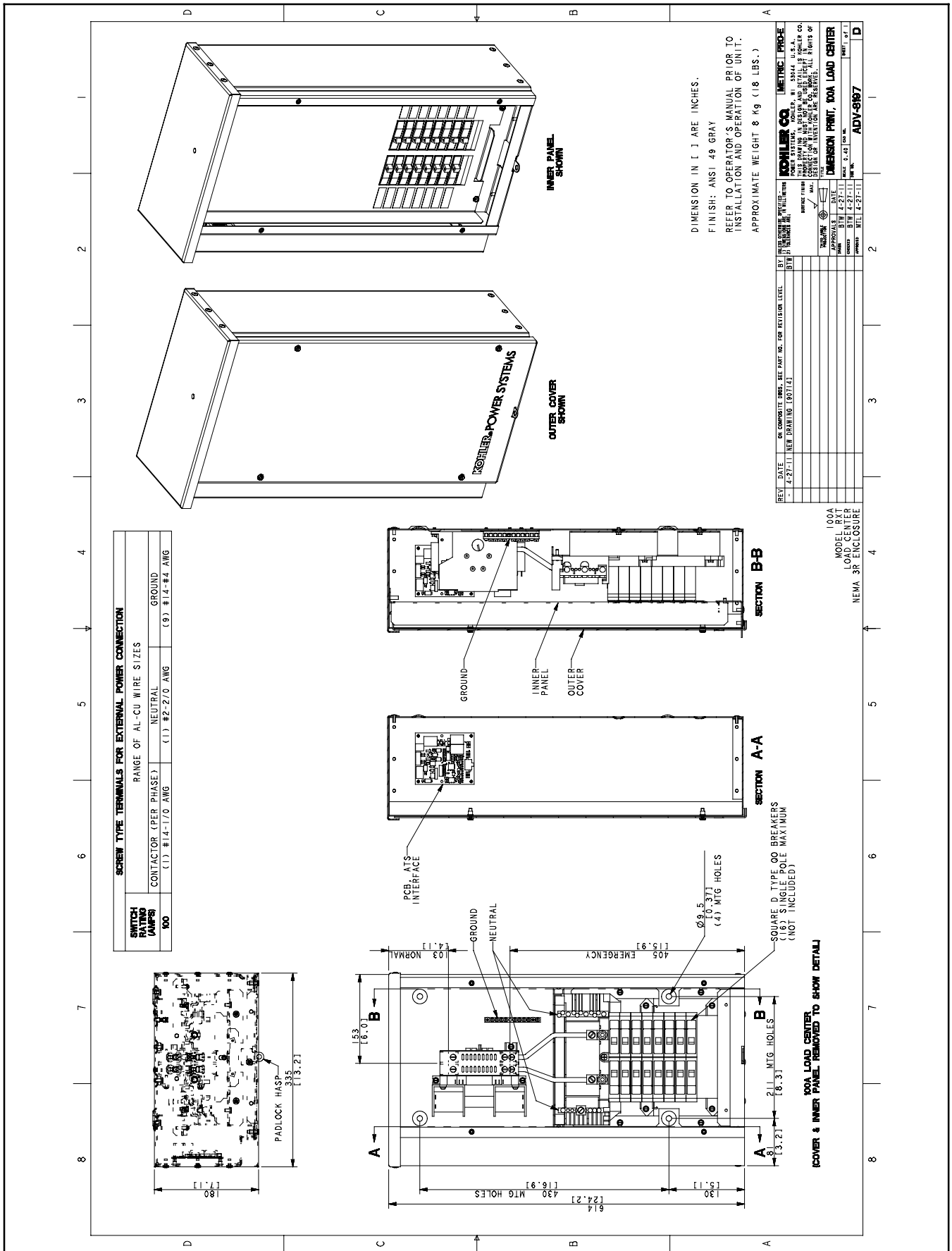

Figure 6-12 Enclosure Dimensions, 100 Amp Single-Phase with Load Center, ADV-8197

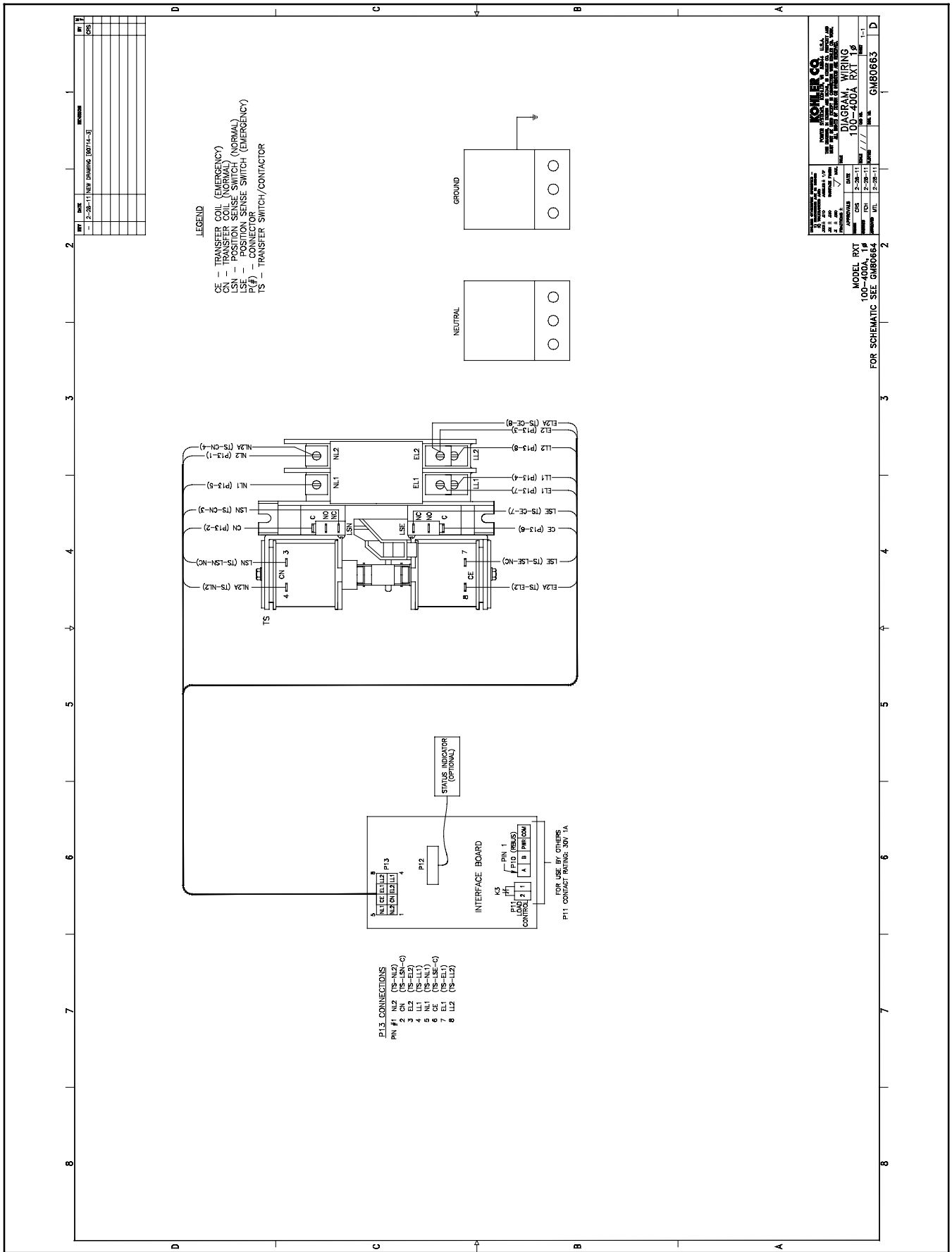

Figure 6-13 Wiring Diagram, 100-400 Amp Single-Phase, GM80663

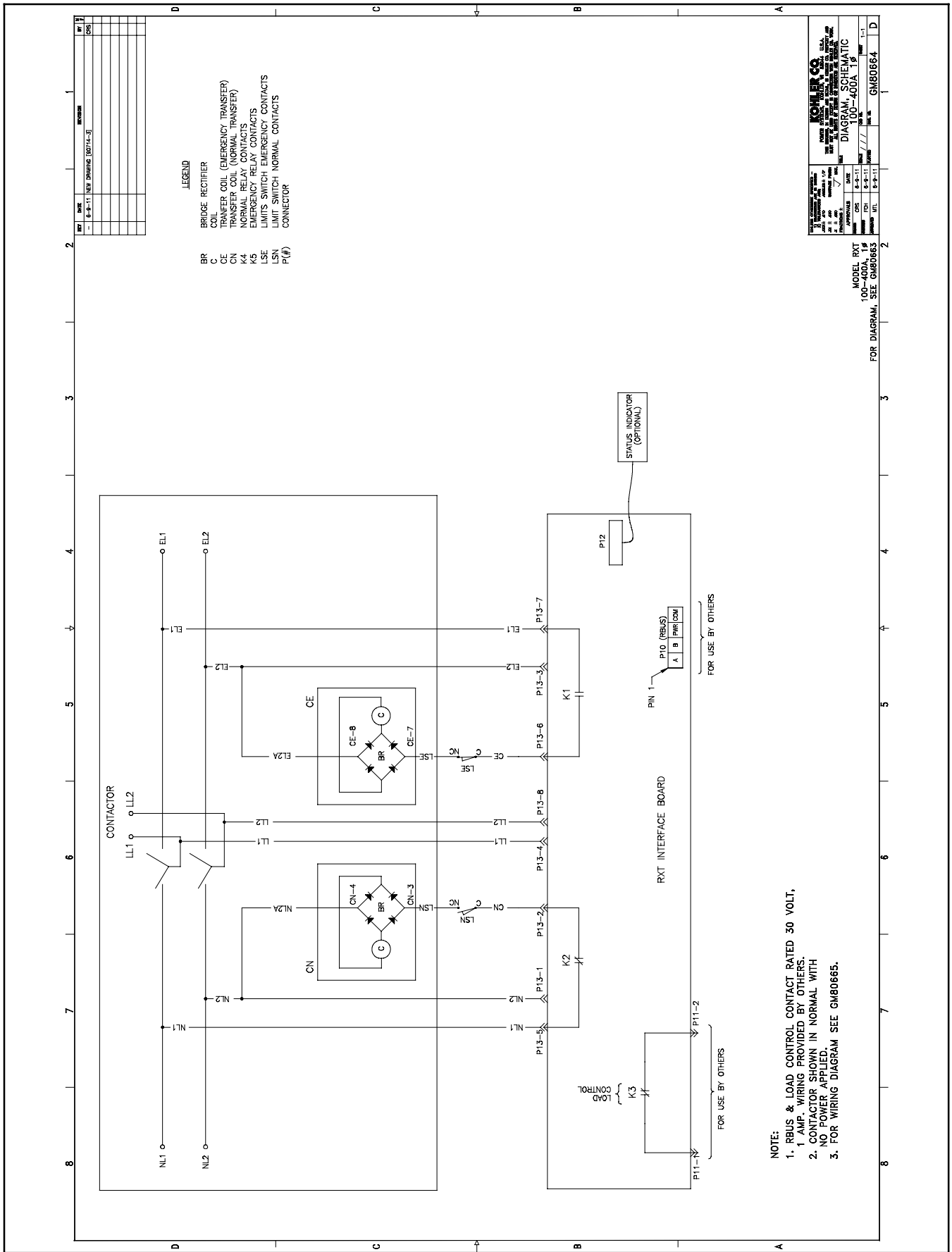

Figure 6-14 Schematic Diagram, 100-400 Amp Single-Phase, GM80664

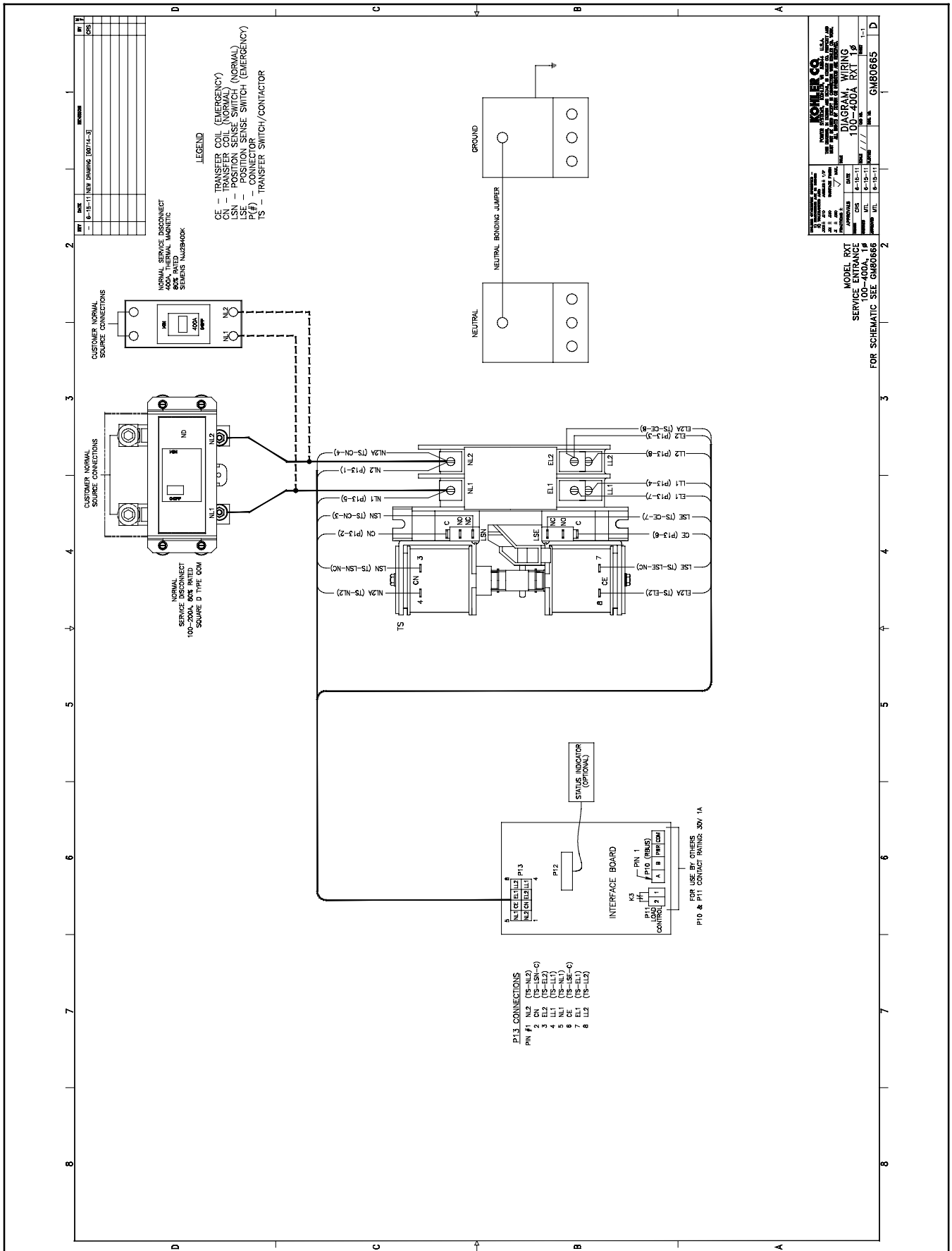

Figure 6-15 Wiring Diagram, 100-400 Amp Service Entrance, GM80665

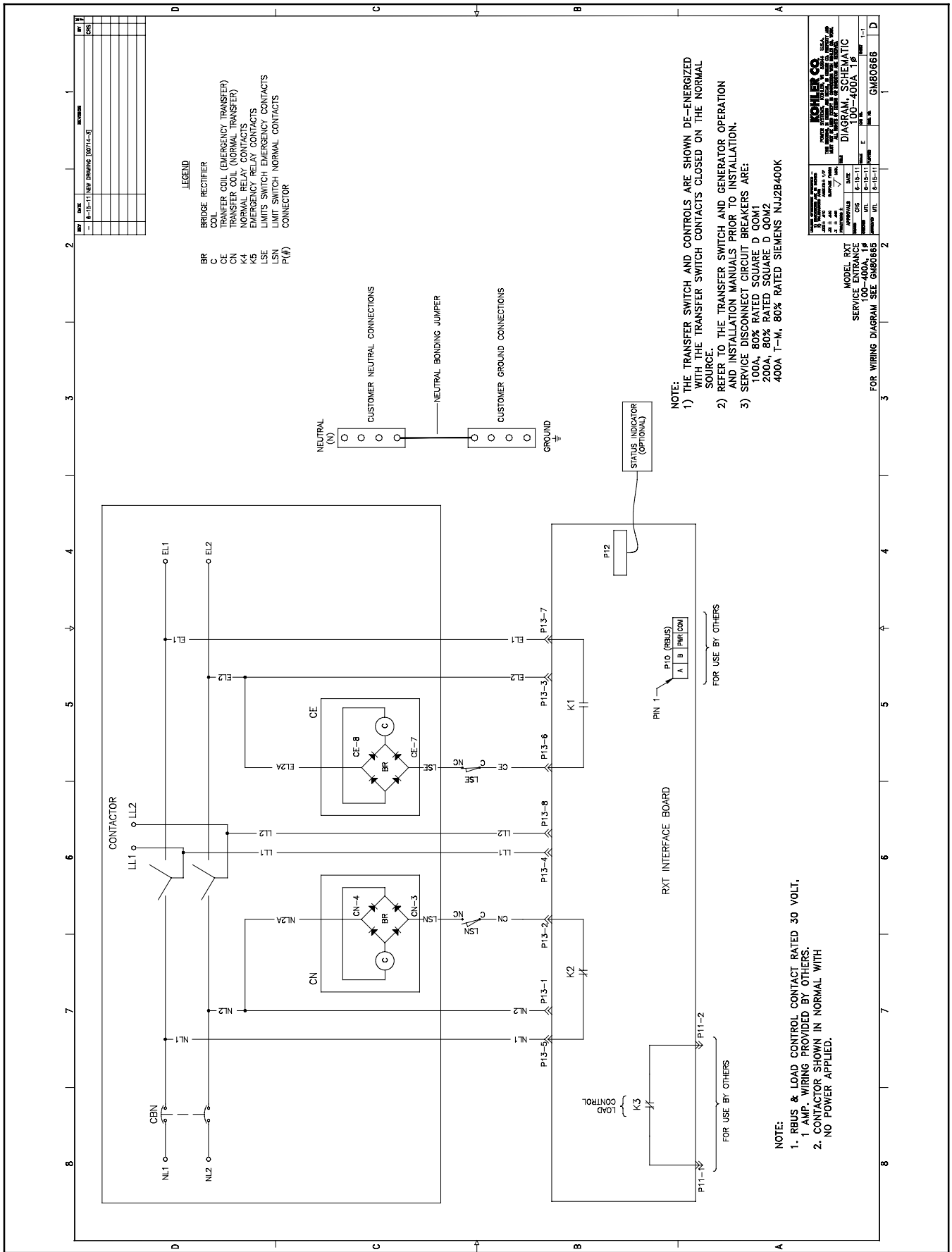

Figure 6-16 Schematic Diagram, 100-400 Amp Service Entrance, GM80666

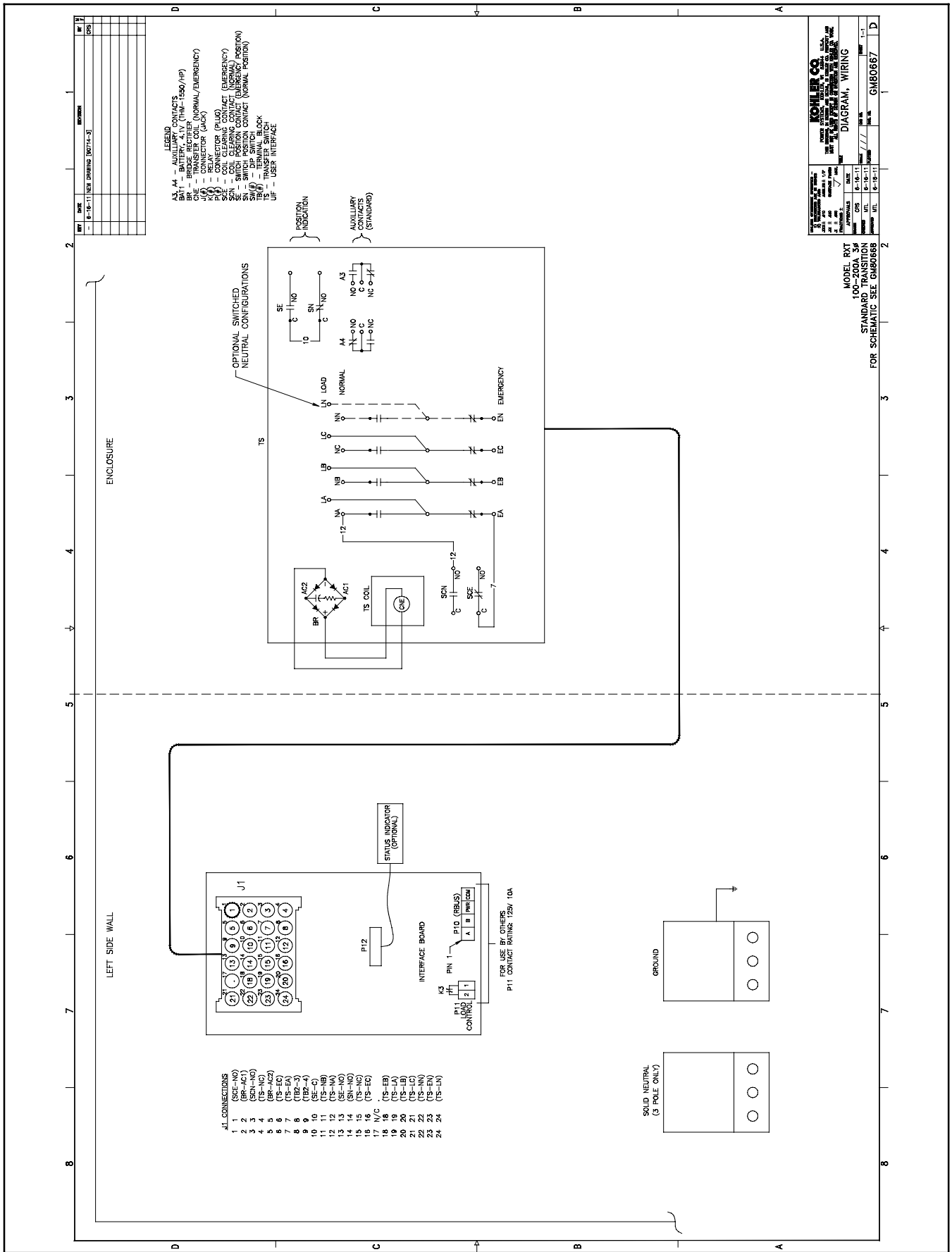
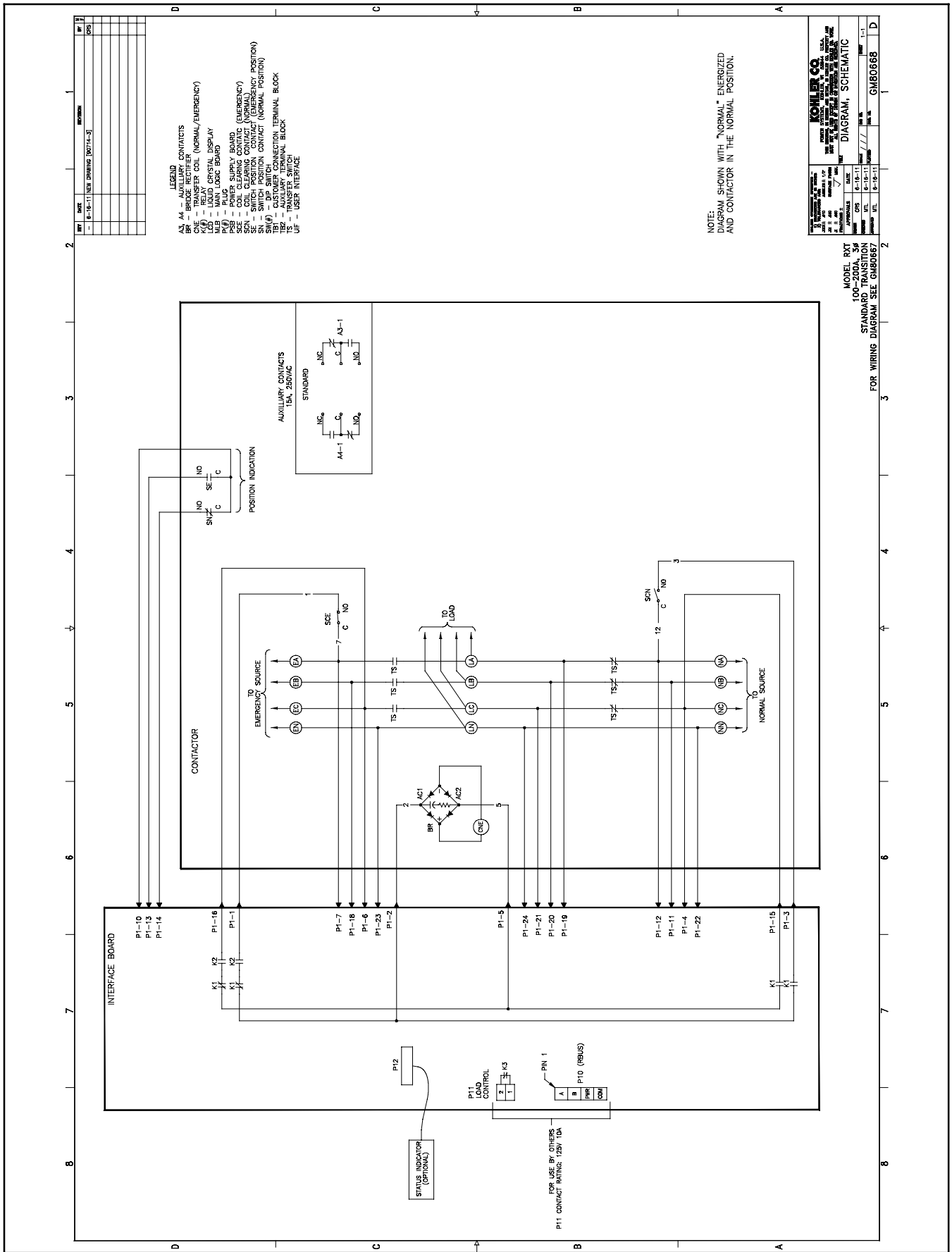

Figure 6-17 Wiring Diagram, 100-200 Amp Three-Phase, 3- and 4-Pole, GM80667



**Figure 6-18** Schematic Diagram, 100-200 Amp Three-Phase, 3- and 4-Pole, GM80668

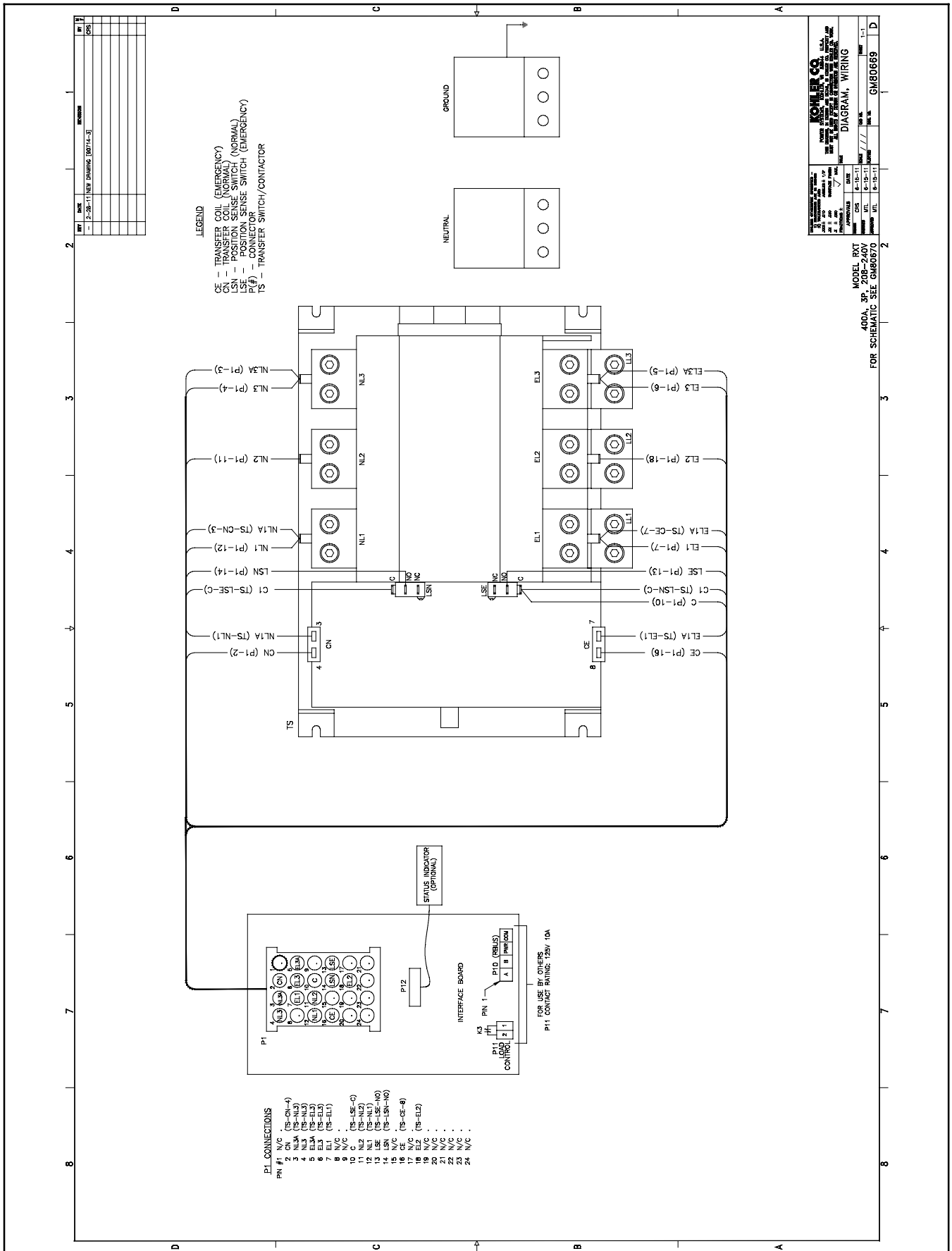

Figure 6-19 Wiring Diagram, 400 Amp Three-Phase, 3-Pole/208-240 Volts, GM80669







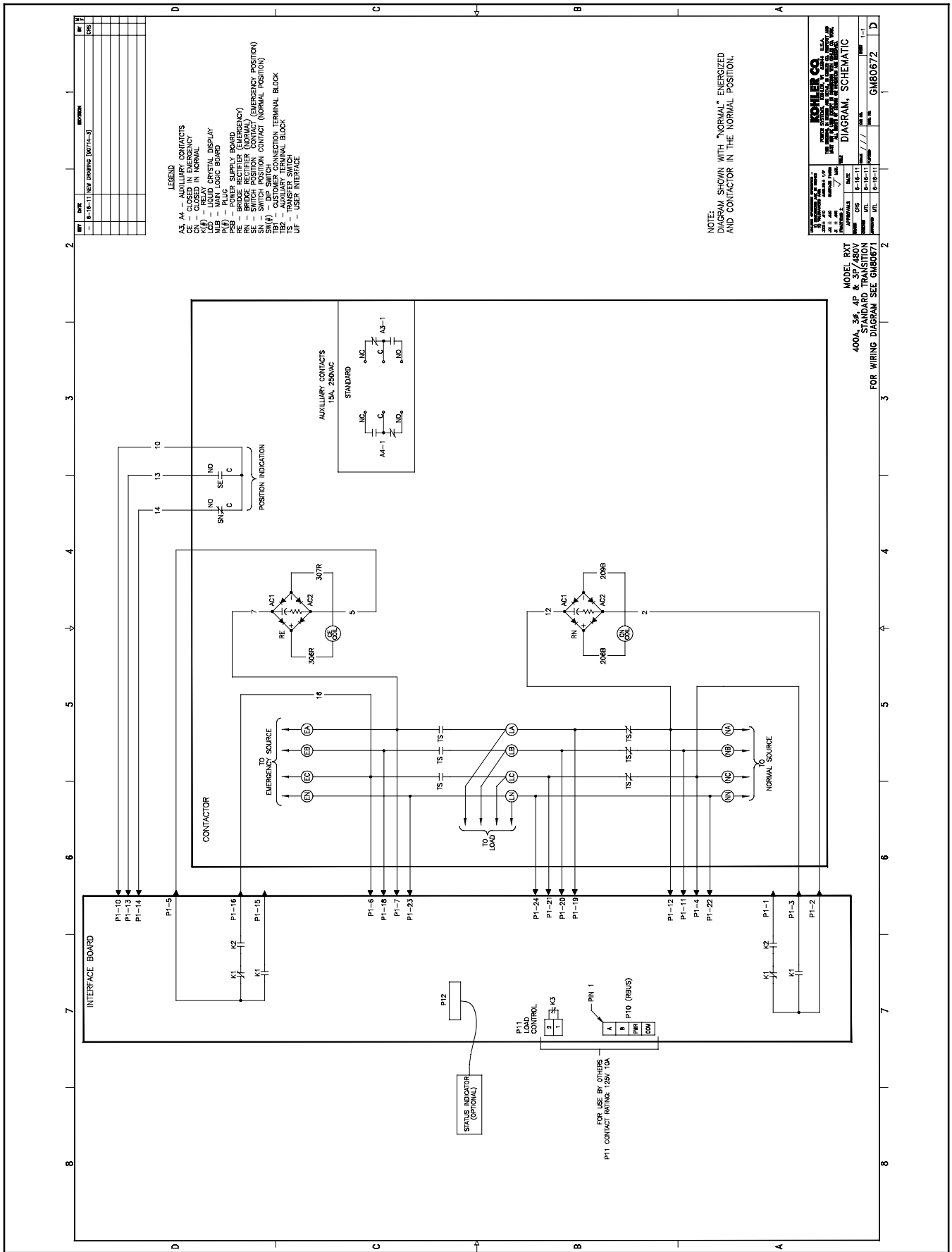

Figure 6-22 Schematic Diagram, 400 Amp Three-Phase, 3-Pole/480 Volts and 4-Pole, GM80672



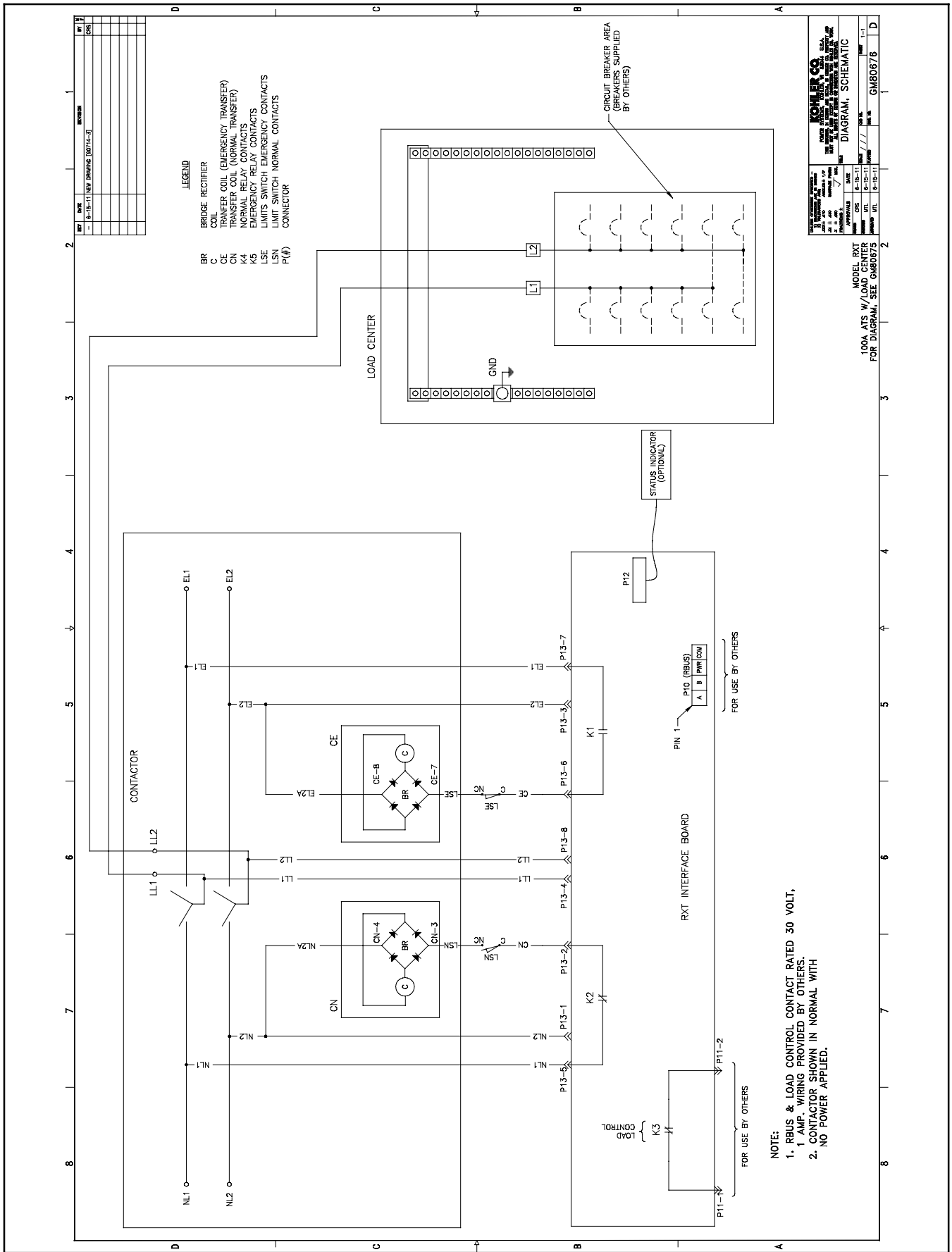

Figure 6-24 Schematic Diagram, 100 Amp Single-Phase with Load Center, GM80676

# Notes

# Appendix A Abbreviations

The following list contains abbreviations that may appear in this publication.

A, amp	ampere	cfm	cubic feet per minute	est.	estimated
ABDC	after bottom dead center	CG	center of gravity	E-Stop	emergency stop
AC	alternating current	CID	cubic inch displacement	etc.	et cetera (and so forth)
A/D	analog to digital	CL	centerline	exh.	exhaust
ADC	advanced digital control; analog to digital converter	cm	centimeter	ext.	external
adj.	adjust, adjustment	CMOS	complementary metal oxide substrate (semiconductor)	F	Fahrenheit, female
ADV	advertising dimensional drawing	cogen.	cogeneration	fglass.	fiberglass
Ah	amp-hour	com	communications (port)	FHM	flat head machine (screw)
AHWT	anticipatory high water temperature	coml	commercial	fl. oz.	fluid ounce
AISI	American Iron and Steel Institute	Coml/Rec	Commercial/Recreational	flex.	flexible
ALOP	anticipatory low oil pressure	conn.	connection	freq.	frequency
alt.	alternator	cont.	continued	FS	full scale
Al	aluminum	CPVC	chlorinated polyvinyl chloride	ft.	foot, feet
ANSI	American National Standards Institute (formerly American Standards Association, ASA)	crit.	critical	ft. lb.	foot pounds (torque)
AO	anticipatory only	CRT	cathode ray tube	ft./min.	feet per minute
APDC	Air Pollution Control District	CSA	Canadian Standards Association	ftp	file transfer protocol
API	American Petroleum Institute	CT	current transformer	g	gram
approx.	approximate, approximately	Cu	copper	ga.	gauge (meters, wire size)
AQMD	Air Quality Management District	cUL	Canadian Underwriter's Laboratories	gal.	gallon
AR	as required, as requested	CUL	Canadian Underwriter's Laboratories	gen.	generator
AS	as supplied, as stated, as suggested	cu. in.	cubic inch	genset	generator set
ASE	American Society of Engineers	cw.	clockwise	GFI	ground fault interrupter
ASME	American Society of Mechanical Engineers	CWC	city water-cooled	GND, ⊕	ground
assy.	assembly	cyl.	cylinder	gov.	governor
ASTM	American Society for Testing Materials	D/A	digital to analog	gph	gallons per hour
ATDC	after top dead center	DAC	digital to analog converter	gpm	gallons per minute
ATS	automatic transfer switch	dB	decibel	gr.	grade, gross
auto.	automatic	dB(A)	decibel (A weighted)	GRD	equipment ground
aux.	auxiliary	DC	direct current	gr. wt.	gross weight
avg.	average	DCR	direct current resistance	H x W x D	height by width by depth
AVR	automatic voltage regulator	deg., °	degree	HC	hex cap
AWG	American Wire Gauge	dept.	department	HCHT	high cylinder head temperature
AWM	appliance wiring material	DFMEA	Design Failure Mode and Effects Analysis	HD	heavy duty
bat.	battery	dia.	diameter	HET	high exhaust temp., high engine temp.
BBDC	before bottom dead center	DI/EO	dual inlet/end outlet	hex	hexagon
BC	battery charger, battery charging	DIN	Deutsches Institut für Normung e. V. (also Deutsche Industrie Normenausschuss)	Hg	mercury (element)
BCA	battery charging alternator	DIP	dual inline package	HH	hex head
BCI	Battery Council International	DPDT	double-pole, double-throw	HHC	hex head cap
BDC	before dead center	DS	disconnect switch	HP	horsepower
BHP	brake horsepower	DVR	digital voltage regulator	hr.	hour
blk.	black (paint color), block (engine)	E, emer.	emergency (power source)	HS	heat shrink
blk. htr.	block heater	ECM	electronic control module, engine control module	hsg.	housing
BMEP	brake mean effective pressure	EDI	electronic data interchange	HVAC	heating, ventilation, and air conditioning
bps	bits per second	EFR	emergency frequency relay	HWT	high water temperature
br.	brass	e.g.	for example ( <i>exempli gratia</i> )	Hz	hertz (cycles per second)
BTDC	before top dead center	EG	electronic governor	IC	integrated circuit
Btu	British thermal unit	EGSA	Electrical Generating Systems Association	ID	inside diameter, identification
Btu/min.	British thermal units per minute	EIA	Electronic Industries Association	IEC	International Electrotechnical Commission
C	Celsius, centigrade	EI/EO	end inlet/end outlet	IEEE	Institute of Electrical and Electronics Engineers
cal.	calorie	EMI	electromagnetic interference	IMS	improved motor starting
CAN	controller area network	emiss.	emission	in.	inch
CARB	California Air Resources Board	eng.	engine	in. H <sub>2</sub> O	inches of water
CB	circuit breaker	EPA	Environmental Protection Agency	in. Hg	inches of mercury
cc	cubic centimeter	ES	engineering special, engineered special	in. lb.	inch pounds
CCA	cold cranking amps	ESD	electrostatic discharge	Inc.	incorporated
ccw.	counterclockwise			ind.	industrial
CEC	Canadian Electrical Code			int.	internal
cert.	certificate, certification, certified			int./ext.	internal/external
cfh	cubic feet per hour			I/O	input/output
				IP	iron pipe
				ISO	International Organization for Standardization
				J	joule
				JIS	Japanese Industry Standard

k	kilo (1000)	MTBO	mean time between overhauls	rms	root mean square
K	kelvin	mtg.	mounting	rnd.	round
kA	kiloampere	MTU	Motoren-und Turbinen-Union	ROM	read only memory
KB	kilobyte (2 <sup>10</sup> bytes)	MW	megawatt	rot.	rotate, rotating
KBus	Kohler communication protocol	mW	milliwatt	rpm	revolutions per minute
kg	kilogram	μF	microfarad	RS	right side
kg/cm <sup>2</sup>	kilograms per square centimeter	N, norm.	normal (power source)	RTU	remote terminal unit
kgm	kilogram-meter	NA	not available, not applicable	RTV	room temperature vulcanization
kg/m <sup>3</sup>	kilograms per cubic meter	nat. gas	natural gas	RW	read/write
kHz	kilohertz	NBS	National Bureau of Standards	SAE	Society of Automotive Engineers
kJ	kilojoule	NC	normally closed	scfm	standard cubic feet per minute
km	kilometer	NEC	National Electrical Code	SCR	silicon controlled rectifier
kOhm, kΩ	kilo-ohm	NEMA	National Electrical Manufacturers Association	s, sec.	second
kPa	kilopascal	NFPA	National Fire Protection Association	SI	<i>Systeme international d'unites</i> , International System of Units
kph	kilometers per hour	Nm	newton meter	SI/EO	side in/end out
kV	kilovolt	NO	normally open	sil.	silencer
kVA	kilovolt ampere	no., nos.	number, numbers	SN	serial number
kVAR	kilovolt ampere reactive	NPS	National Pipe, Straight	SNMP	simple network management protocol
kW	kilowatt	NPSC	National Pipe, Straight-coupling	SPDT	single-pole, double-throw
kWh	kilowatt-hour	NPT	National Standard taper pipe thread per general use	SPST	single-pole, single-throw
kWm	kilowatt mechanical	NPTF	National Pipe, Taper-Fine	spec	specification
kWth	kilowatt-thermal	NR	not required, normal relay	specs	specification(s)
L	liter	ns	nanosecond	sq.	square
LAN	local area network	OC	overcrank	sq. cm	square centimeter
L x W x H	length by width by height	OD	outside diameter	sq. in.	square inch
lb.	pound, pounds	OEM	original equipment manufacturer	SS	stainless steel
lbm/ft <sup>3</sup>	pounds mass per cubic feet	OF	overfrequency	std.	standard
LCB	line circuit breaker	opt.	option, optional	stl.	steel
LCD	liquid crystal display	OS	oversize, overspeed	tach.	tachometer
ld. shd.	load shed	OSHA	Occupational Safety and Health Administration	TD	time delay
LED	light emitting diode	OV	overvoltage	TDC	top dead center
Lph	liters per hour	oz.	ounce	TDEC	time delay engine cooldown
Lpm	liters per minute	p., pp.	page, pages	TDEN	time delay emergency to normal
LOP	low oil pressure	PC	personal computer	TDES	time delay engine start
LP	liquefied petroleum	PCB	printed circuit board	TDNE	time delay normal to emergency
LPG	liquefied petroleum gas	pF	picofarad	TDOE	time delay off to emergency
LS	left side	PF	power factor	TDON	time delay off to normal
L <sub>wa</sub>	sound power level, A weighted	ph., ∅	phase	temp.	temperature
LWL	low water level	PHC	Phillips® head Crimptite® (screw)	term.	terminal
LWT	low water temperature	PHH	Phillips® hex head (screw)	THD	total harmonic distortion
m	meter, milli (1/1000)	PHM	pan head machine (screw)	TIF	telephone influence factor
M	mega (10 <sup>6</sup> when used with SI units), male	PLC	programmable logic control	TIR	total indicator reading
m <sup>3</sup>	cubic meter	PMG	permanent magnet generator	tol.	tolerance
m <sup>3</sup> /hr.	cubic meters per hour	pot	potentiometer, potential	turbo.	turbocharger
m <sup>3</sup> /min.	cubic meters per minute	ppm	parts per million	typ.	typical (same in multiple locations)
mA	milliampere	PROM	programmable read-only memory	UF	underfrequency
man.	manual	psi	pounds per square inch	UHF	ultrahigh frequency
max.	maximum	psig	pounds per square inch gauge	UL	Underwriter's Laboratories, Inc.
MB	megabyte (2 <sup>20</sup> bytes)	pt.	pint	UNC	unified coarse thread (was NC)
MCCB	molded-case circuit breaker	PTC	positive temperature coefficient	UNF	unified fine thread (was NF)
MCM	one thousand circular mils	PTO	power takeoff	univ.	universal
meggar	megohmmeter	PVC	polyvinyl chloride	US	undersize, underspeed
MHz	megahertz	qt.	quart, quarts	UV	ultraviolet, undervoltage
mi.	mile	qty.	quantity	V	volt
mil	one one-thousandth of an inch	R	replacement (emergency) power source	VAC	volts alternating current
min.	minimum, minute	rad.	radiator, radius	VAR	voltampere reactive
misc.	miscellaneous	RAM	random access memory	VDC	volts direct current
MJ	megajoule	RDO	relay driver output	VFD	vacuum fluorescent display
mJ	millijoule	ref.	reference	VGA	video graphics adapter
mm	millimeter	rem.	remote	VHF	very high frequency
mOhm, mΩ	milliohm	Res/Coml	Residential/Commercial	W	watt
MOhm, MΩ	megohm	RFI	radio frequency interference	WCR	withstand and closing rating
MOV	metal oxide varistor	RH	round head	w/	with
MPa	megapascal	RHM	round head machine (screw)	w/o	without
mpg	miles per gallon	rly.	relay	wt.	weight
mph	miles per hour			xfmr	transformer
MS	military standard				
ms	millisecond				
m/sec.	meters per second				
MTBF	mean time between failure				



# Notes

# Notes



**TP-6807 12/11**

© 2011 by Kohler Co. All rights reserved.

# **KOHLER**<sup>®</sup> POWER SYSTEMS

KOHLER CO. Kohler, Wisconsin 53044  
Phone 920-457-4441, Fax 920-459-1646  
For the nearest sales/service outlet in the  
US and Canada, phone 1-800-544-2444  
KohlerPower.com

Kohler Power Systems  
Asia Pacific Headquarters  
7 Jurong Pier Road  
Singapore 619159  
Phone (65) 6264-6422, Fax (65) 6264-6455